

grapevine™

**grapevine**

Research  
System  
User  
Manual  
CE

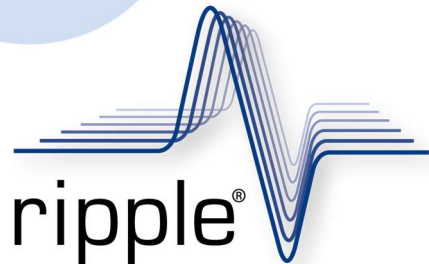

Salt Lake City, UT, USA



This document was, as far as possible, accurate at the time of release, though subsequent changes may have been made to the software and hardware. Ripple reserves the right to alter specifications and details as required. Late-breaking information may be supplied separately for completeness.

**Note: Please refer to Grapevine Trek sections for usage instructions and technical information regarding the legacy Grapevine Nomad or new Explorer Summit, Quest HD, or Quest HD+Stim processors.**

### **Trademarks of Ripple**

ripple, ripple neuro, ripple neuromed, grapevine, and explorer are registered trademarks of Ripple. The names of specific devices, such as Summit, Trek, Quest HD, and MIRA are trademarks of Ripple.

### **Other Trademarks**

Bi-Lobe is a registered trademark of Omnetics Connector Corporation.  
Apple, Mac, Macintosh, and OS X are registered trademarks of Apple Computer, Inc.  
Windows is a registered trademark of Microsoft Corporation.  
Linux is a registered trademark of Linus Torvalds.  
LEMO is a registered trademark of LEMO USA, Inc.  
MATLAB is a registered trademark of The MathWorks, Inc.  
Intel is a registered trademark of Intel Corporation.  
NETGEAR is a registered trademark of NETGEAR, Inc.  
Onanon is a trademark of Onanon, Inc.

All other trademarks are the property of their respective owners.

Product: Grapevine Neural Interface System

Copyright © February 2021 Ripple, LLC  
2056 South 1100 East, Salt Lake City, UT 84106, USA

All rights reserved. No part of this document may be reproduced by any means without the prior written permission of Ripple.

Website: [www.rippleneck.com](http://www.rippleneck.com)  
Technical Support: [support@rppl.com](mailto:support@rppl.com)

Release – Document Version LBL-0044\_18









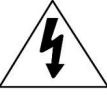

**NOTE: The systems described in this manual are NOT medical devices and are NOT cleared by the FDA for use with humans.**

**For information about using these systems with humans under IRB or IDE research protocols please contact Ripple.**

## Grapevine NIP Human Use Considerations

The Grapevine Neural Interface System described herein, **with exceptions noted**, has been designed for use with human subjects. The system has been used with humans through Institutional Review Board approval at various universities and institutions. Ripple has tested all components of the Grapevine Neural Interface System for isolation and leakage current per IEC-60601-1 standards. Components of the system that are not intended for human use are specifically noted throughout this manual.

## Standard Symbols in Use

	IEC 60101-0102	Danger of Electrostatic Discharge (ESD)		IEC 60417-5031	Direct Current
	IEC 60417-5036	Dangerous Voltage		IEC 60417-5032	Alternating Current
	IEC 60417-5335	Type CF Applied Part		IEC 60417-5021	Equipotentiality Connector
	EN-980	Warning		IEC 60417-5008	OFF (power)
	EN-980	Serial Number		IEC 60417-0007	ON (power)

## Specifications

Power Requirements	110 VAC at 60 Hz or 240 VAC at 50 Hz, 8 A max load
Serviceable Fuses	5 x 20 mm, 250 V, 2 A, Slow Blow (Scout processor only)
Compliance Standards	EU Directive 2004/108/EC (EMC) and Directive 2006/95/EC (LVD) EN 61326-1:2013 (EMC), EN 55011 (EMC), EN 61010-1:2010 (LVD)
Type of Protection	Class II
Degree of Protection	Type CF Applied Part
Mode of Operation	Continuous
Water Ingress Protection	Ordinary Equipment, not fluid resistant, IP20
Operating Environment	10 °C to 40 °C, 5 to 95% R.H. (non-condensing)
Storage Environment	-20 °C to 50 °C, 5 to 100% R.H. (non-condensing)













## Grapevine Trek Human Use Considerations

**Note: Please refer to Grapevine Trek sections for usage instructions and technical information regarding the legacy Grapevine Nomad or new Explorer Summit, Quest HD, or Quest HD+Stim processors.**

The Grapevine Trek System described herein has been designed for use with human subjects. The patient **is not** the intended operator.

The Grapevine Trek System is a research device and should not be used to treat nor diagnose medical conditions. Due to this research-only use, the Grapevine Trek System does not have any Essential Performance requirements and will remain safe for use on research subjects even if the device shuts down. The system is designed to provide electrical safety even when not powered, and stimulation outputs are designed to safely shut down immediately in cases of loss of power, digital communication interruptions or errors, excessive power draw, or massive ESD events. Researchers should ensure that their specific experiment does not have additional Essential Performance requirements and do adequate testing to ensure safety of their research subjects for any modifications or additions to the system.

### Standard Symbols in Use

	IEC 60101-0102	Danger of Electrostatic Discharge (ESD)		IEC 60417-5031	Direct Current
	IEC 60417-5036	Dangerous Voltage		IEC 60417-5032	Alternating Current
	IEC 60417-5333	Type BF Applied Part		IEC 60417-5021	Equipotentiality Connector
	EN-980	Warning		IEC 60417-5010	“ON” / “OFF” (push-push)
	EN-980	Serial Number		IEC 60417-5017	Earth (ground)
	IEC 60417-5172	Class II Equipment		EN-50419	Waste Electrical and Electronic Equipment
	ASTM F2503	MR Unsafe			

## Grapevine Trek Human Use Considerations

Ripple has tested the Grapevine Trek System and passed the relevant portions of IEC 60601-1 and IEC 60601-1-2 standards for use in both Hospital/Laboratory Environments and Home Healthcare Environments. Included in these tests were isolation and leakage current, temperature, ESD, dielectric strength, and electromagnetic compatibility.

### Specifications

Power Requirements	110 VAC at 60 Hz or 240 VAC at 50 Hz, 1 A max load
Compliance Standards	IEC 60601-1:2012 IEC 60601-1-2 EN 55011 Class B Group 1 AIM 7135152 (No deviations were used)
Type of Protection	Class II
Degree of Protection	Type BF Applied Part
Mode of Operation	Continuous
Water Ingress Protection	Ordinary Equipment, not fluid resistant, IP20
Operating Environment	10 °C to 27 °C, 5 to 95% R.H. (non-condensing)
Storage Environment	-20 °C to 50 °C, 5 to 100% R.H. (non-condensing)
Wireless Connectivity	IEEE 802.11ac 5.15-5.35 GHz EIRP 17dBm (50mW) FCC ID: PPD-QCNFA34AC

**NOTE: The Grapevine Scout is not approved for human use.**

## Warnings

- The Grapevine system should only be used with components provided or approved by Ripple.
- Use of accessories, transducers, and cables other than those specified or provided by the manufacturer of this equipment could result in increased electromagnetic emissions or decreased electromagnetic immunity of this equipment and result in improper operation.
- Ripple supplied cables and accessories maintain compliance with tested standards.
- Do not ingest any components of the Grapevine system.
- Only connect the Grapevine system to properly tested and grounded AC outlets. Do not connect the Grapevine system components to an outlet controlled by a wall switch.
- Do not use the Grapevine system in the presence of flammable gases.
- Keep all components of the Grapevine system away from liquids. Contact with water can lead to electric shock.
- The Grapevine system is not sterile. It may be used in conjunction with sterile devices but should be kept outside sterile environments.
- The Grapevine system may be used with third-party components approved by Ripple. Follow all manufacturer recommendations for third-party components as improper use can compromise the safety of the Grapevine system components.
- The Grapevine system has not been formally tested for interference in the vicinity of EAS systems and metal detectors. Due to their concealment, users should only operate the system in an environment known to not include these EAS systems.
- The Grapevine system is MR Unsafe – keep away from magnetic resonance imaging (MRI) equipment.
- Use of this equipment adjacent to or stacked with other equipment should be avoided because it could result in improper operation. If such use is necessary, this equipment and the other equipment should be observed to verify that they are operating normally.
- Portable RF communications equipment (including peripherals such as antenna cables and external antennas) should be used no closer than 30 cm (12 inches) to any part of the **Grapevine Trek**, including cables specified by Ripple. Otherwise, degradation of the performance of this equipment could result.
- The **Grapevine Trek** contains a Lithium battery pack. IEC 62133 certification is available upon request.
- The **Grapevine NIP** has some components that can reach high temperatures. To reduce the likelihood of skin burns, operators should ensure that the device will not come into direct contact with a patient at any time and should not be touched by the user for more than one second while it is in use.



## Electrostatic Discharge Instructions

Grapevine system components that are sensitive to electrostatic discharge are marked with the ESD symbol. For these Grapevine components, users should not directly touch any internal pins and should adhere to the following precautions when connecting electrodes or adapters to these components. Users should always ground themselves before handling these Grapevine components. Users should then ground the Grapevine component before connecting to electrodes or adapters by touching the screw terminals of the component cable or by touching the metal shell of the component. Users should ensure that the subject is properly grounded before connecting the Grapevine component to electrodes attached to the subject.

## Product Cleaning

Grapevine components should only be cleaned with lightly wetted cloths using water or alcohol. Grapevine components should not be immersed in or sprayed with any liquids or gases.

## Warranty

Products provided by Ripple are warranted to be free from defects in materials and manufacturing for a period of one year from the date of shipment (five years for Grapevine Processors). This warranty is voided by abuse, negligent handling, or misapplication of the product, or modifications to the product by persons not authorized by Ripple. Any product that does not comply with this warranty shall be replaced or repaired at the option of Ripple. Unless addressed in a separate agreement, this constitutes the sole warranty provided by Ripple and there are no other warranties, expressed or implied, which extend beyond those described herein or to anyone other than the original purchaser, including the implied warranties of merchantability and fitness for a particular purpose. In no event shall Ripple be liable for any direct, indirect, incidental or consequential damages, or for the infringement of any patent rights or third-party rights, due to the use of its products or consulting and design services.

## System Calibration and Diagnostics

Grapevine processors contain no user-serviceable or removable parts. Ripple recommends that the processor be sent in once a year for a full diagnostic check-up by Ripple engineers. There is no cost for the diagnostic check-up outside of normal shipping costs.

## Return Merchandise Authorization (RMA) Process

Ripple Grapevine products that require maintenance or repair should be returned to the address below only after receiving a Return Merchandise Authorization number from Ripple Support (support@rppl.com or +1-801-413-0139). Grapevine components should be shipped to Ripple in secure, anti-static, padded packaging. Ripple recommends that users keep all original Grapevine packaging in case of repair or maintenance needs.

Ripple | 2056 South 1100 East | Salt Lake City, UT 84106 USA

## Acronyms and Abbreviations

NIP	Grapevine Neural Interface Processor, Grapevine NIP
Scout	Grapevine Scout Processor, Grapevine Scout
Trek	Grapevine Trek Processor, Grapevine Trek
FE	Grapevine Front End, Front End Module
AIO	Grapevine Analog I/O Front End, Analog I/O FE
DIO	Grapevine Digital I/O Front End, Digital I/O FE
ADIO	Grapevine Analog+Digital I/O Front End, Analog+Digital I/O FE

**CONTENTS**

**CHAPTER 1 HARDWARE OVERVIEW ..... 12**

- How to Use This Manual..... 12**
- Grapevine Neural Interface System ..... 12**
- Hardware Requirements ..... 13**
- Operating System Requirements..... 13**
- Understanding Grapevine System Components..... 13**
  - Neural Interface Processor (NIP)..... 13
  - Front End Interface Cables ..... 18
  - Front Ends..... 18
    - Nano Style FEs..... 18*
    - Pico Style FEs..... 18*
    - Micro Style FEs..... 19*
    - EMG..... 19*
    - EEG and Macro Style FEs ..... 19*
    - Link Style FEs..... 19*
    - Digital I/O..... 23*
    - Analog I/O..... 25*
    - Analog+Digital I/O..... 27*
  - Scout Processor ..... 29
  - Trek Processor ..... 30

**CHAPTER 2 INSTALLATION AND SETUP ..... 37**

- Connecting the Hardware..... 37**
  - Direct Connection to Computer ..... 37
  - Multiple Computer Connections to the Processor ..... 37
  - Windows 7 Network Configuration ..... 38
  - Mac OS X Network Configuration..... 40
  - Linux Network Configuration..... 41

**CHAPTER 3 TRELIS SOFTWARE SUITE ..... 42**

- Using Trellis Software..... 42**
- Instruments ..... 43**
  - Network Info..... 46
  - Electrode-Channel Map Files ..... 46
  - Instrument Configuration ..... 47
    - *Data Streams ..... 47*
    - *Saved Configurations ..... 48*
    - *Global Auto Thresholding..... 48*
    - *Digital I/O Options..... 49*
    - *Analog Outputs..... 49*
    - *Digital Outputs ..... 49*
    - *Fast Settle Triggers ..... 49*
    - *Filter Settings..... 50*
    - *Front-End User-Controlled Hardware Settings..... 51*
    - *Stimulation Lookup Tables ..... 51*
- Applications..... 52**
  - Raster ..... 52
  - Spike Grid..... 54
    - Heat Map Display..... 55*
  - Spike Scope..... 56
  - Impedance Analyzer ..... 60
- File Save ..... 69**

<b>Two Processor Synchronization</b> .....	72
<b>APPENDIX A TECHNICAL INFORMATION</b> .....	76
<b>Supported Front Ends</b> .....	76
Nano2, Nano2-HV, Nano2+Stim, and Nano2+Stim HC .....	76
Pico16+Stim, Pico16-HV, Pico32+Stim, Pico32-HV, Pico32 .....	77
Micro2, Micro2-HV, Micro2+Stim, and Micro2+Stim HC .....	79
Explorer Macro+Stim .....	80
Explorer EEG .....	81
Link 32 .....	81
EMG .....	81
Digital I/O .....	82
Analog I/O .....	83
Analog+Digital I/O .....	84
<b>Legacy Front Ends</b> .....	85
Nano .....	85
Micro, Micro-HV, and Micro+Stim .....	85
Surf S2 .....	86
Surf S .....	86
Surf D .....	87
<b>APPENDIX B SYSTEM INFORMATION</b> .....	88
<b>Trellis Software</b> .....	88
<b>Grapevine Processors and Front Ends</b> .....	89
<b>APPENDIX C HARDWARE &amp; SOFTWARE CONFIGURATION</b> .....	92
<b>Hardware</b> .....	92
<b>Trellis Software Suite</b> .....	93
<b>Trellis Configuration File</b> .....	94
<b>APPENDIX D ADDITIONAL SOFTWARE COMPONENTS</b> .....	95
<b>MATLAB®</b> .....	95
<b>Open Source MATLAB®</b> .....	95
<b>Python</b> .....	96
<b>C</b> .....	96
<b>Third-Party Software Compatibility</b> .....	96
<b>APPENDIX E ADAPTERS</b> .....	97
<b>Samtec-Omnetics</b> .....	97
<b>Front End Cable Saver</b> .....	97
<b>Touchproof</b> .....	97
<b>EMU</b> .....	97
<b>Screw-Terminals for Single-Wire Electrodes</b> .....	98
<b>Electrode Adapter Rod</b> .....	98
<b>Analog I/O and Digital I/O Breakouts</b> .....	98
<b>Utah Array Pedestal Connector</b> .....	99
<b>Recording Front End Tester</b> .....	100
<b>Stimulation Front End Tester</b> .....	100
<b>APPENDIX F TROUBLESHOOTING GUIDE</b> .....	101
<b>APPENDIX G REVISION HISTORY</b> .....	102

# Hardware Overview



## How to Use This Manual

The chapters and appendices in this manual provide an overview of the Grapevine system hardware, technical information on the Grapevine components, instructions on the installation and use of the Trellis software suite, and additional information on system configuration. This document is not intended as a service manual. The specifications and diagrams that are provided in this manual are to assist users in understanding the capabilities of the Grapevine system. Only authorized Ripple employees and representatives are qualified to repair any component of the system. All rights of the warranty for said component are voided if any other party modifies any component without the written consent of Ripple.

## Grapevine Neural Interface System

The Grapevine system is comprised of several components that can be used for the acquisition of electrophysiological and neurophysiological data. At the heart of the system is a Grapevine processor. Currently there are three models of Grapevine processor: NIP, Trek, and Scout. The processor interfaces with up to sixteen Front Ends (FEs) which filter, amplify, and digitize signals from both high-impedance and low-impedance electrodes. Example electrodes include microelectrodes, bare wire electrodes, surface electrodes, etc. The processor also interfaces with FEs that provide analog and digital I/O capabilities. The processor can only be used with Grapevine FEs manufactured by Ripple. The processor connects to a computer via a gigabit Ethernet connection. The Trellis software suite provides an interface for controlling instrument settings, data recording, stimulation, and visualization of acquired data. The generalized Grapevine system workflow is shown below.

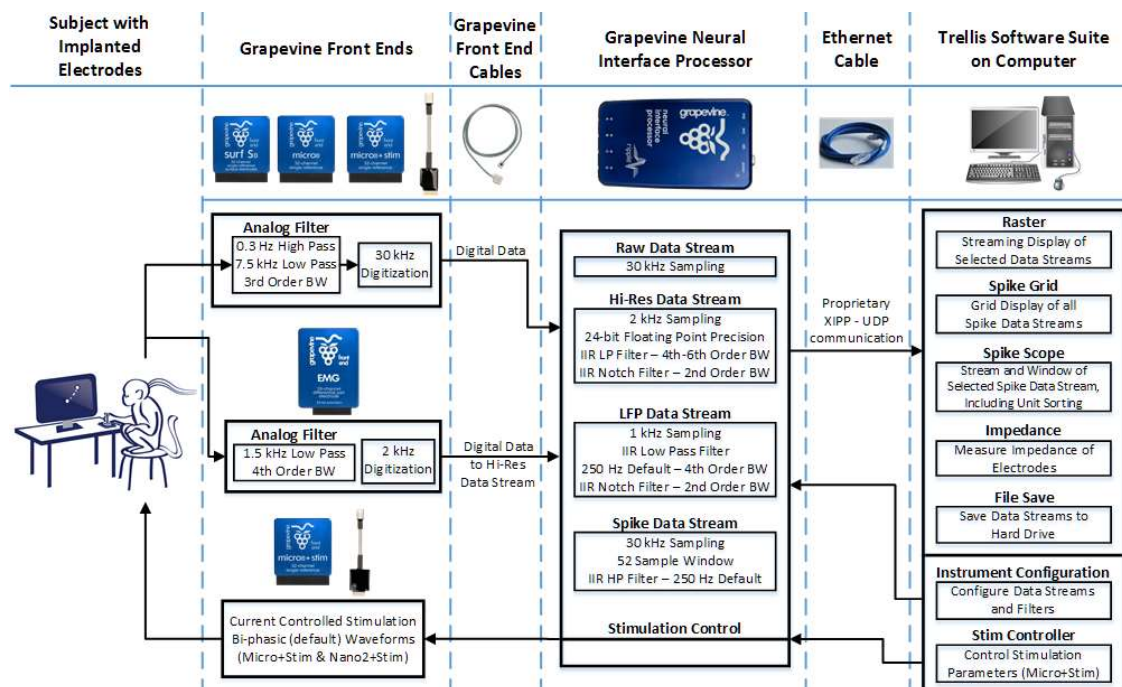

Figure 1-1 Schematic of the Grapevine system workflow



## Hardware Requirements

The Grapevine system has the following hardware requirements for any computer that is intended to stream, visualize, and record up to 512 channels of data.

### *Minimum Requirements*

Processor:	Intel Core2Duo or greater
Memory:	4 GB RAM or greater
Network Interface Card:	1 GB Adapter
Wireless Adapter:	802.11ac (Trek only)
Graphics Card:	Intel HD 620 or greater for high channel counts

### *Recommended Components*

Internal Storage:	2 TB or greater
External Storage:	One or more 2 TB or greater eSATA (external SATA) drive(s)

## Operating System Requirements

The Grapevine Trellis software suite is designed to run on Microsoft (Windows 7, 10), Apple Macintosh [Mac OSX (10.7-10.13)], and Linux (Ubuntu 18.04 64-bit) platforms.

## Understanding Grapevine System Components

### Neural Interface Processor (NIP)

The Grapevine Neural Interface Processor (NIP) supports up to sixteen Grapevine Front Ends (FEs). This section describes the different connectors, indicators, and features of the NIP.

#### *Top Panel*

The top panel of the NIP provides terminals and ports for interfacing with a power supply, UDP network, expansion ports, and auxiliary control interfaces. The top panel is also where the power button can be found.

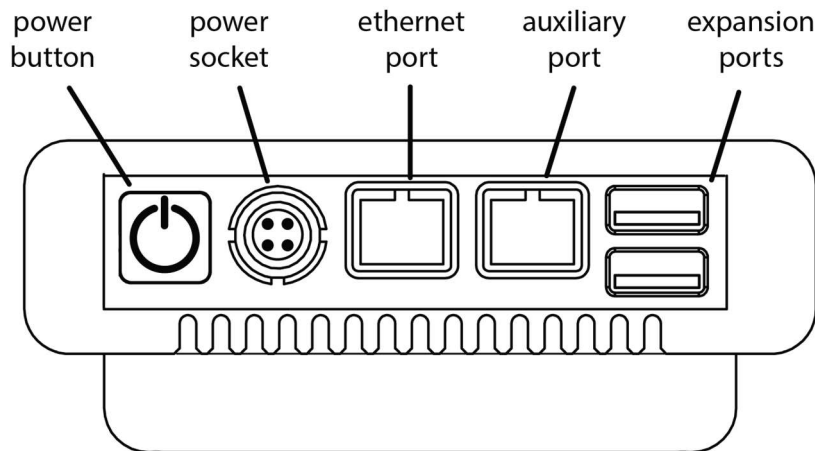

Figure 1-2 Top panel of the Grapevine NIP



## Power Connections

The power button, on the left of the top panel, toggles the power status of the NIP. The 4-pin LEMO® circular power socket is used to connect the NIP to an isolated medical power supply that is provided with the processor. The power supply uses a 3-pin IEC power socket to connect to a 3-pin earthed (grounded) power cable. The power supply can be used in all common international main power supplies, between 100-240 V AC at 50-60 Hz.

## Ethernet Port

The Ethernet port connects the NIP to a computer. This enables the NIP to transmit data being acquired from the FEs to the Trellis software, as well as control signals from the Trellis software to be sent to the NIP. A network switch may also be used to enable control of a single NIP by multiple computers running Trellis software and/or other NIP control software.

## Auxiliary Port

The auxiliary port is used to synchronize multiple NIPs to create a greater than 512-channel recording and stimulation system. Contact Ripple for questions on how the auxiliary port may be used for unique applications.

## Expansion Ports

The Grapevine NIP is fitted with two USB-type expansion ports for applying device updates. Due to power limitations, only devices that have been explicitly approved by Ripple can be safely connected to the expansion ports on the Grapevine NIP.

## Bottom Panel

The bottom panel of the Grapevine NIP provides the Front End ports to attach Grapevine FEs.

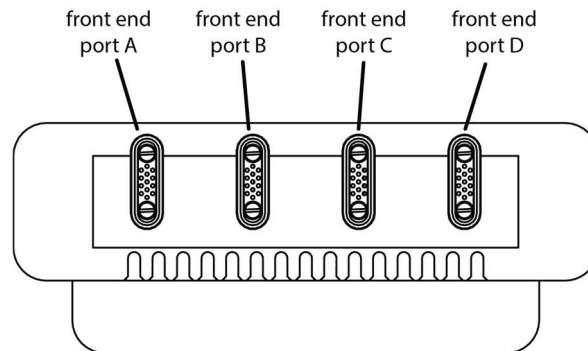

**Figure 1-3** Bottom panel of the Grapevine NIP

## Front End Ports

There are a total of four Front End ports that can each be connected to up to four Grapevine FEs via single, double, triple, or quadruple Front End cables. In total, the four ports enable a single NIP to support up to sixteen FEs. **Note:** Currently, only one Analog I/O FE and one Digital I/O FE can be connected to the NIP. **Note:** Front End cables should be removed from the port by squeezing and pulling the release tab on the connector only; do not pull on the cable.



### Front Panel

The front panel of the Grapevine NIP provides labeling for all of the connectors on the top and bottom panels of the unit. There are a total of five indicator lights – one for the unit’s power status and four for the status of the Front End ports.

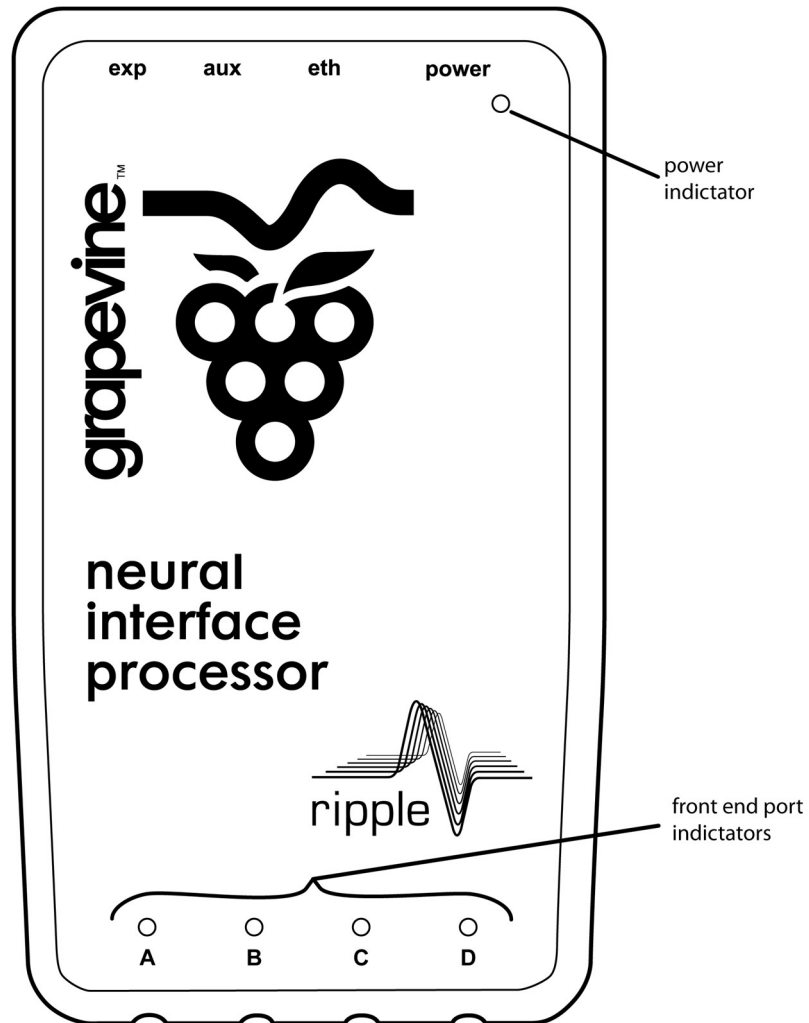

Figure 1-4 Front panel of the Grapevine NIP



## Power Indicator LED

The power indicator LED will turn blue and then orange when the power supply is plugged into the Grapevine NIP, indicating that the NIP is in startup mode. After a few seconds, this light will turn green to indicate that the NIP has initialized and is streaming data. When the NIP is not initialized, the power indicator will be blue to show that the unit is in standby mode. The light will only turn off when the power supply is unplugged from the unit.

**Table 1-1** Power Indicator states

Status Indicator	Meaning
Off	No power. The Grapevine NIP is not plugged in.
Blue	Standby. The NIP is plugged in but not ready for recording.
Green	Streaming. The NIP is sending data over the network for visualization and capture.
Orange	Initializing. The Grapevine is powered on and initializing.
Orange/Red Blinking	2-NIP synchronization error state.

## Front End Port Indicators

The Front End port indicator LEDs will turn green when a Front End cable attached to a functioning FE is connected to a Front End port. **Note:** All desired FEs must be connected to Front End ports before the NIP is powered on.

**Table 1-2** Front end port indicator status

Status Indicator	Meaning
Off	No connection. No Grapevine Front End cable is connected to the port or the connected Front End cable is not properly configured.
Green	Connected. The Front End cable is connected to the port and properly configured.
Orange	Error.
Red	Fault. Generally this occurs when a power supply has detected excessive power draw. If this occurs, shutdown the system for safety.





### **Back Panel**

The back panel of the NIP is where the speaker and cooling fan are located. **Note:** The speaker is not currently used by the NIP. **Note:** The VGA plate (next to the speaker) should remain attached at all times. The VGA port beneath is for Ripple development and testing purposes only.

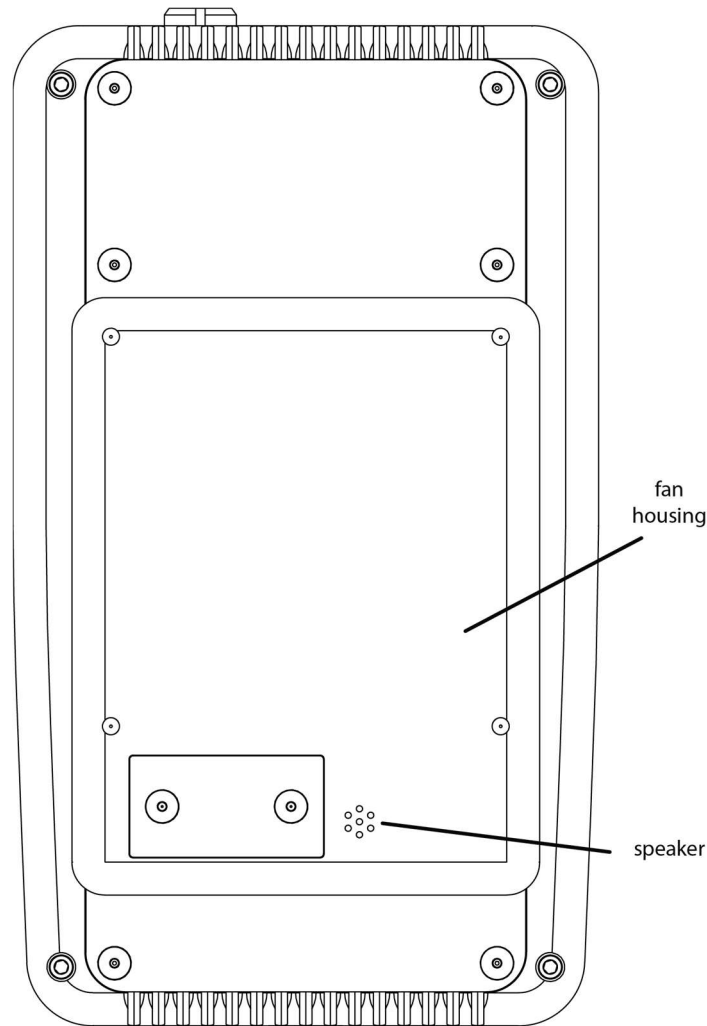

**Figure 1-5** Back panel of the Grapevine NIP

### **Fan Housing**

To ensure the continuous operation of the Grapevine NIP, the housing is designed to act as a heat sink. The enclosed cooling fan provides sufficient airflow to maintain the electronics performing at standard operating temperatures. **Note:** The fan may change speeds to manage the system temperature. The vents on the top and bottom of the NIP allow air to flow and must not be obstructed by dust or other devices, as this may impede ventilation and cooling. Any obstruction of airflow may degrade the performance of the NIP, or even permanently damage the unit.



## Front End Interface Cables

The Front End cables included with the Grapevine system should be handled with care. Damage can occur if users pull on the gray insulation wrapping. Cables should only be disconnected from Grapevine processors and Front Ends using the following instructions. To disconnect the cable from a Grapevine processor, pinch the LEMO connector and pull the connector gently from the processor. Front End cables for the Trek can be disconnected by grasping the Onanon connector and pulling it straight out of the Front End port. To disconnect the BiLobe connector cable from a Front End (Micros, EMG, and previous generation FEs), unscrew the two bolts from the Omnetics BiLobe connector. When both bolts are fully free, the connector will come free from the Front End without any effort. The Grapevine Nano2 Front Ends use a circular Omnetics connector that mates and disconnects with minimal force.

**Note:** All FE positions in a double, triple, or quadruple Front End cable must be occupied in order for the device to be initialized properly.

## Front Ends

There are a variety of Grapevine Front Ends (FEs) that connect the Grapevine processor to electrodes, as well as analog and digital signals. The electrode recording FEs perform filtering, amplification, and analog-to-digital conversion for the signals that they collect. The Analog I/O FE is capable of acquiring and producing  $\pm 5$  V analog signals. The Digital I/O FE is capable of acquiring and producing LVTTTL data. A total of 16 Grapevine FEs can be interfaced with a single Grapevine NIP, enabling up to 512 channels of data streaming, recording, and stimulation. Each of the Grapevine FEs and their function are explained below. All technical specifications of these FEs can be found in Appendix A.

**Note:** Some newer stim variant FEs require lookup tables to perform stimulation. Please refer to Chapter 3 for more information regarding ‘stimulation lookup tables’.

### ***Nano Style FEs***

The Grapevine Nano Front Ends record from up to 32 electrodes. These Front Ends have a small form factor and low weight, making them suitable for all animal applications, including small rodents. The Nano2+Stim and Nano2+Stim HC also deliver current-controlled stimulation (simultaneously with recording) through up to 32 high-impedance microelectrodes. The Nano2+Stim HC is similar to the Nano2+Stim and allows for additional charge injection. The Nano2-HV is similar to the Nano2 and includes additional circuitry for high-voltage protection in applications where nearby stimulation may occur.

**CAUTION: The Grapevine Nano (v1) FE is not intended for human clinical or research use.**

### ***Pico Style FEs***

The Grapevine Pico Front Ends record from up to 32 electrodes. They are lightweight and designed for recording through microelectrode arrays in animals. The Pico16+Stim and Pico32+Stim also deliver current-controlled stimulation (simultaneously with recording) through up to 32 high-impedance microelectrodes.



### Micro Style FEs

The Grapevine Micro Front Ends record from up to 32 electrodes. They are designed for recording through microelectrode arrays, micro-ECoG grids, and other peripheral and cortical neural electrodes. The Micro+Stim, Micro2+Stim, and Micro2+Stim HC also deliver current-controlled stimulation (simultaneously with recording) through up to 32 high-impedance microelectrodes. The Micro2+Stim HC is similar to the Micro2+Stim and allows for additional charge injection. The Micro-HV and Micro2-HV are similar to the Micro and Micro2 and include additional circuitry for high-voltage protection in applications where nearby stimulation may occur.

### EMG

The Grapevine EMG records from up to 16 differential electrodes. It is designed for surface and implanted differential signals, such as bipolar EMG.

### EEG and Macro Style FEs

The Explorer EEG and Macro style FEs record from up to 32 electrodes. They are designed for monopolar surface recordings (EEG), ECoG, and SEEG recording and stimulation. The EEG+tES and Macro+Stim FEs deliver current-controlled stimulation (simultaneously with recording) through up to 32 electrodes.

**Note:** All FEs have been internally tested to meet the standard leakage and isolation requirements. The Grapevine Micro FEs and EMG have additional safety protection.

### Link Style FEs

The Grapevine Link Front Ends consist of an implantable recording device paired with an external wireless transceiver for transmission of power and data. These Front Ends are designed for signals such as EMG or ECoG and record at a 2 kS/s sampling rate.

### Front End to NIP Connector (Grapevine Micros and EMG)

The top panel contains the status indicator and an Omnetics Bi-Lobe® terminal to connect the FE to a Front End cable. The status indicator on the Grapevine FE will turn green when a FE is properly connected to the Grapevine processor and initialized.

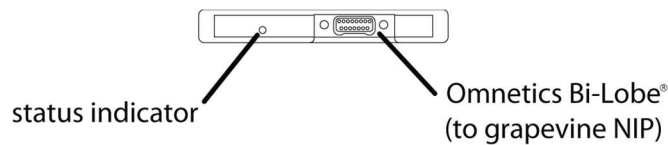

**Figure 1-6** Top panel of the Grapevine FE (Micros and EMG)

Status Indicator	Meaning
Off	No connection. Either the FE is not properly connected to a Front End cable or the cable is not connected to an active Grapevine processor.



Green	Connected. The FE is properly connected to the Front End cable and the cable is connected to an active Grapevine processor.
Orange	Initialization or Error.

**Table 1-3** Grapevine FE status indicator (Micros and EMG)

### Front End to Electrode Connector (Grapevine Micros and EMG)

The bottom panel of the Grapevine FE contains the 36-pin Samtec connector for interfacing with electrode platforms. Adapter boards may be required to connect some electrodes. A pinout diagram of the 36-pin Samtec connector can be found in Appendix A. The 36-pin Samtec connector on the Grapevine Micros and EMG has 32 pins for recording electrode connections, 2 pins for reference electrodes and 2 pins for ground connections. All of the recording electrodes are referenced to a single reference electrode, which is selectable with reference selection switches on the back of the Grapevine FE. Refer to Table 1-4 for information on selecting references. The 36-pin Samtec connector on the Grapevine EMG has 32 pins for recording 16 pairs of electrodes, and 2 pins for ground connections. Each of the recording electrodes is paired with a unique reference electrode, which is specified in the Grapevine EMG pinout diagram found in Appendix A.

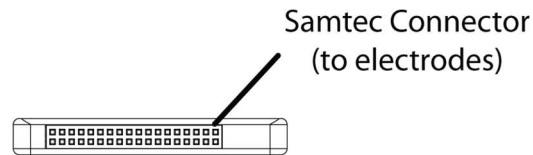

**Figure 1-7** Bottom panel of the Grapevine FE (Micros and EMG)

### Front End Front Panel (Grapevine Micros and EMG)

The front panel contains markings and labels that identify the Grapevine FE.

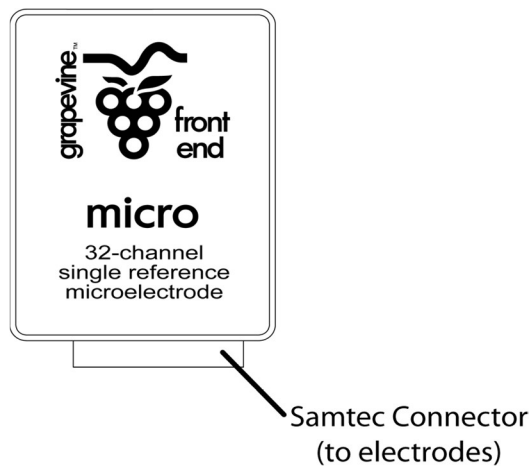
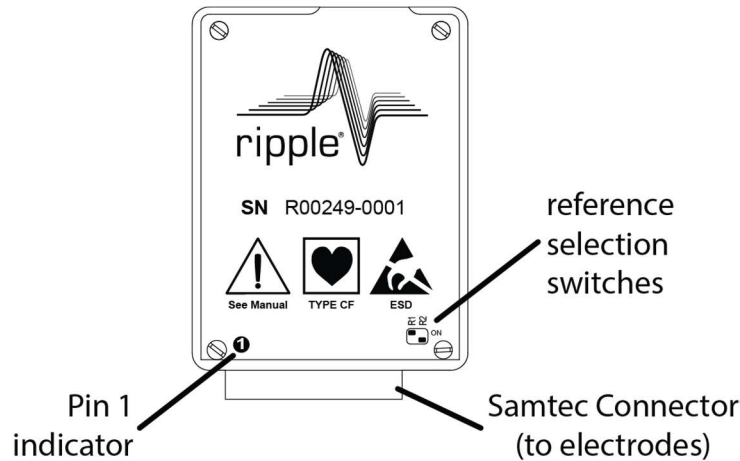

**Figure 1-8** Front panel of the Grapevine FE (Micro shown, similar for EMG)



## Front End Back Panel (Grapevine Micros and EMG)

The back panel of the Grapevine FE contains markings and labels relating to the device certification, an ESD warning, and a label directing the user to read the manual (see preface for ESD user instructions). A label to identify pin 1 of the FE is found on the bottom left corner of the back panel. When connecting the FE to electrodes or adapter boards, it is necessary to ensure that pin 1 on the FE aligns with pin 1 on the electrode connector or adapter board. Additionally, the back panel contains the switches to select a configuration for the reference pins (except for the EMG Front End which has no reference switches). Reference selection is explained in Table 1-4.



**Figure 1-9** Back panel of the Grapevine FE (Micros and EMG)  
**Note:** The EMG does not have reference selection switches

## Front End Front Panel (Grapevine Nano FEs)

The connectors, pin 1 indicator, and reference selection switches are visible on the front panel of the Grapevine Nano Front Ends. The Grapevine Nano FEs use a 36-position Omnetics connector to interface with implanted microelectrode platforms. Adapter boards may be required to connect to some electrodes. A pinout diagram of the connector can be found in Appendix A. The 40-pin Omnetics connector has 32 pins for recording electrode connections, 2 pins for reference electrodes, 2 pins for ground connections, and 4 guide pins. All of the recording electrodes are referenced to a single reference electrode, which is selectable with reference selection switches on the front of the Grapevine Nano style FEs. Reference selection is explained in Table 1-4.

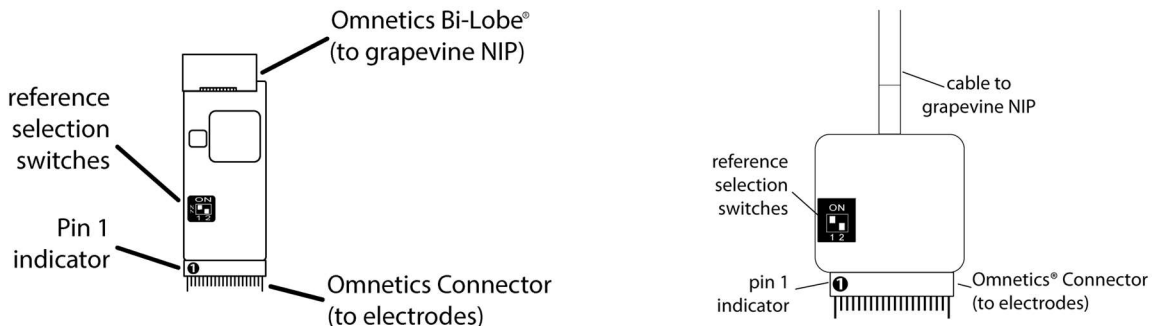

**Figure 1-10** Front panel of the Grapevine Nano FEs (Nano left, Nano2 right)



## Reference Selection Switches

All of the recording electrodes for the Grapevine Micro and Nano FEs are referenced to a single reference electrode, which is determined by setting the reference selection switches on the Grapevine FE. Table 1-4 below explains the reference selection switches.

**Table 1-4** Grapevine FE reference selection switch states

Switch 1	Switch 2	Meaning
Down	Down	No reference is connected; the reference is floating. <b>Not Recommended</b> as it typically results in increased noise.
Up	Down	Reference pin R1 is selected as the reference electrode. Reference pin R2 is ignored.
Down	Up	Reference pin R2 is selected as the reference electrode. Reference pin R1 is ignored.
Up	Up	Reference pins R1 and R2 are tied together and used as the reference electrode. This can be used with a compatible adapter to create a reference bus.



## **Digital I/O**

The Grapevine Digital I/O Front End (DIO for short) enables the Grapevine processor to interface with LVTTTL digital devices. The DIO has 20 inputs that can be connected to the outputs of other digital devices. Signals recorded by the DIO are synchronized with data recorded from other Grapevine FEs. All digital inputs can be used for triggering various functions of the Trellis software suite. The DIO has 20 outputs that can be used to trigger other devices. All grounds in the DIO are tied together internally, minimizing grounding issues. The front panel of the DIO contains markings and labels that identify the Grapevine FE, as well as labels indicating the function of each port. The DIO comes with four mounting holes that allow the device to be mounted to a wall or rack (with #4 screws, not included). For detailed specifications of the Grapevine Digital I/O Front End, see Appendix A.

### **Digital I/O connectors**

The top panel contains the Micro-D connector used to connect the DIO to the Grapevine processor, via a Front End I/O cable. The bottom panel of the DIO contains a mini RS-232 serial I/O port that is currently not operational but may be enabled in a future release.

The left side panel contains the connectors and ports for digital inputs. The DIO has 4 SMA input ports that accept LVTTTL inputs at up to 10 kS/s (kilosamples per second). Each port supports one channel of digital data that is synchronized with data acquired from other Grapevine FEs. The DIO also has a 25-pin Micro-D connector that supports 16 bits of digital input on a single cable.

The right side panel contains the connectors and ports for LVTTTL digital outputs. The Trellis software suite includes an interface by which the Grapevine processor can be configured to route spike events out of individual digital output ports. The DIO has 4 SMA output ports and a 25-pin Micro-D output port, similar to the input side. See the ‘Instruments > Digital Outputs’ section of Chapter 3 for detailed information on digital output event markers.

In addition, Ripple produces the Grapevine Digital BNC Breakout adapter (PN: R01396) that connects to the 25-pin Micro-D port (either input or output) and houses 18 BNC terminals for simple connection of up to 16 digital and 2 strobe inputs. More detailed specifications for this connector, including pinout information, can be found in Appendix A. Contact Ripple for specialized cabling needs.

**Note:** Only one Digital I/O Front End can be connected to an NIP or Trek. The Scout Processor has a built-in Digital I/O and cannot have additional Digital I/O Front Ends connected.

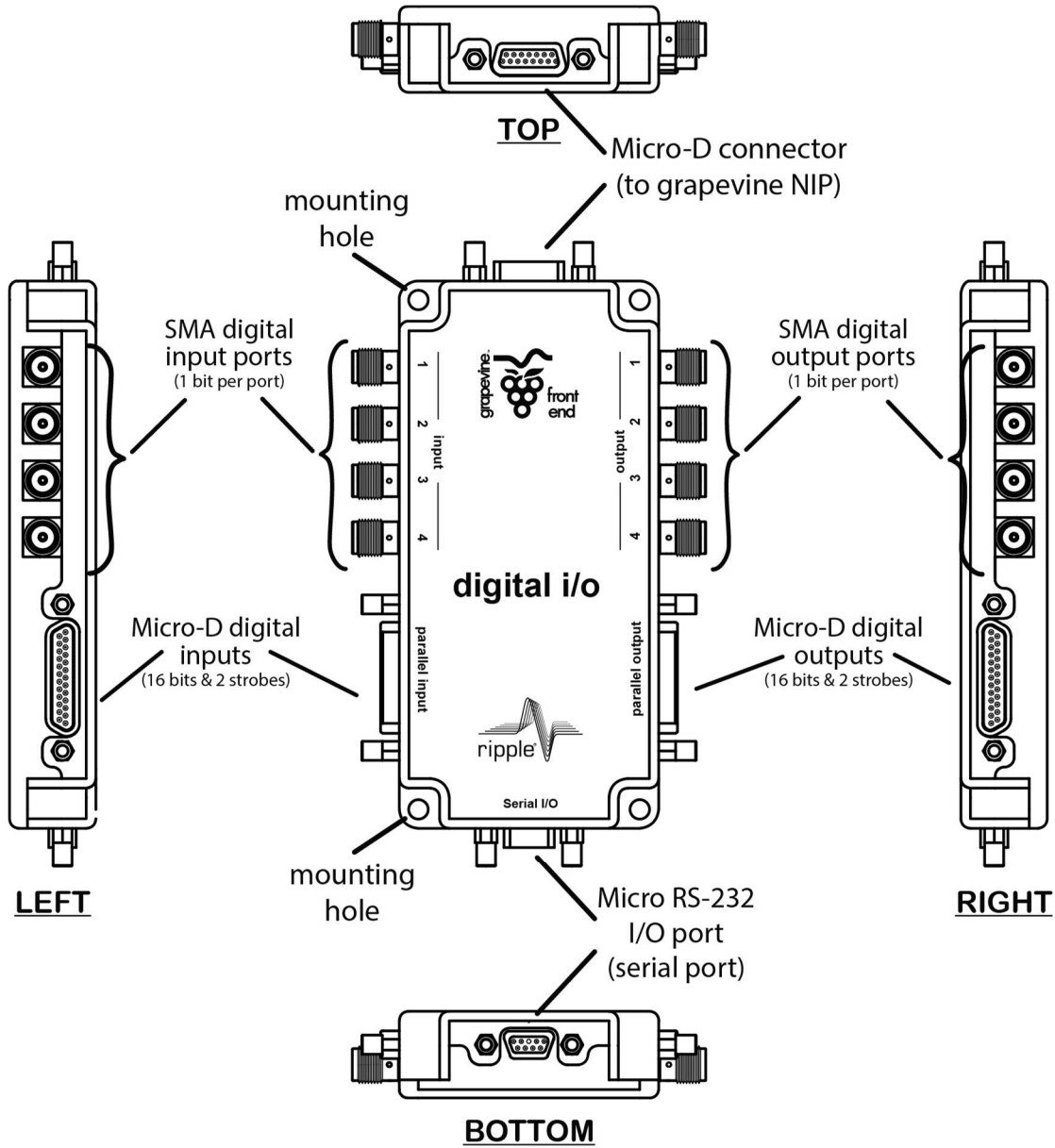

Figure 1-11 Complete set of views for the Grapevine Digital I/O Front End (DIO)





## Analog I/O

The Grapevine Analog I/O Front End (AIO for short) enables the Grapevine processor to interface with analog devices. The AIO has 28 inputs with a  $\pm 5$  V range that can be connected to the analog output of other devices. Signals recorded by the AIO are synchronized with data recorded from other Grapevine FEs. The AIO also has 28 outputs that enable signals collected with the Grapevine processor to be routed to external devices. Additionally, the AIO comes with a single stereo audio input port and two stereo audio output ports. All of the grounds on the AIO are tied together internally to minimize grounding issues. The front panel of the AIO contains markings and labels that identify the FE, as well as labels indicating the function of each port. The AIO comes with four mounting holes that allow the device to be mounted to a wall or rack (using #4 screws, not included). For detailed specifications of the Grapevine Analog I/O Front End, see Appendix A.

### Analog I/O Connectors

The top panel contains the Micro-D connector used to connect the AIO to the Grapevine NIP, via a Front End I/O cable. The bottom panel provides three 3.5 mm stereo audio jacks. The leftmost of these jacks is used for 2 channels of audio input that are acquired by the Grapevine processor, in sync with data being acquired from other Grapevine FEs. The other two jacks provide 4 channels of audio output (2 channels on each jack). This allows for up to four channels of spiking activity to be played from attached speakers.

The left side panel contains all of the connectors and ports for analog inputs. The AIO has 4 SMA analog input ports and a 25-pin Micro-D connector to enable up to 24 additional analog inputs on a single cable.

The right side panel of the AIO contains 4 SMA ports and a 25-pin Micro-D connector for analog outputs. A signal acquired by any FE can be reproduced on any analog output channel, scalable up to  $\pm 5$  V. See the ‘Instruments > Analog Outputs’ section of Chapter 3 for detailed information on analog output routing of continuous data streams.

In addition, Ripple produces the Grapevine Analog BNC Breakout adapter (PN: R01124) that connects to the 25-pin Micro-D port (either input or output) and houses 24 BNC terminals and a ground reference. More detailed specifications for this connector, including pinout information, can be found in Appendix A. Contact Ripple for specialized cabling needs.

**Note:** Only one Analog I/O Front End can be connected to an NIP or Trek processor. The Scout Processor has a built-in Analog I/O and cannot have additional Analog I/O Front Ends connected

**Note:** Due to hardware revisions, an Analog I/O Front End **must have** a hardware version 4 or greater to be compatible with a Trek processor. Hardware version of an Analog I/O can be checked by connecting it to your processor and checking the full name in the Instrument Tree of Trellis.

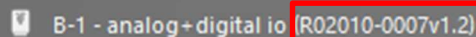
A screenshot of the Instrument Tree in Trellis. The text 'B-1 - analog+digital io' is followed by a red-bordered box containing the text 'R02010-0007v1.2'.

B-1 - analog+digital io R02010-0007v1.2

Example: ADIO (R02010-0007) is Hardware Version 1, Software Version 2 (v1.2)

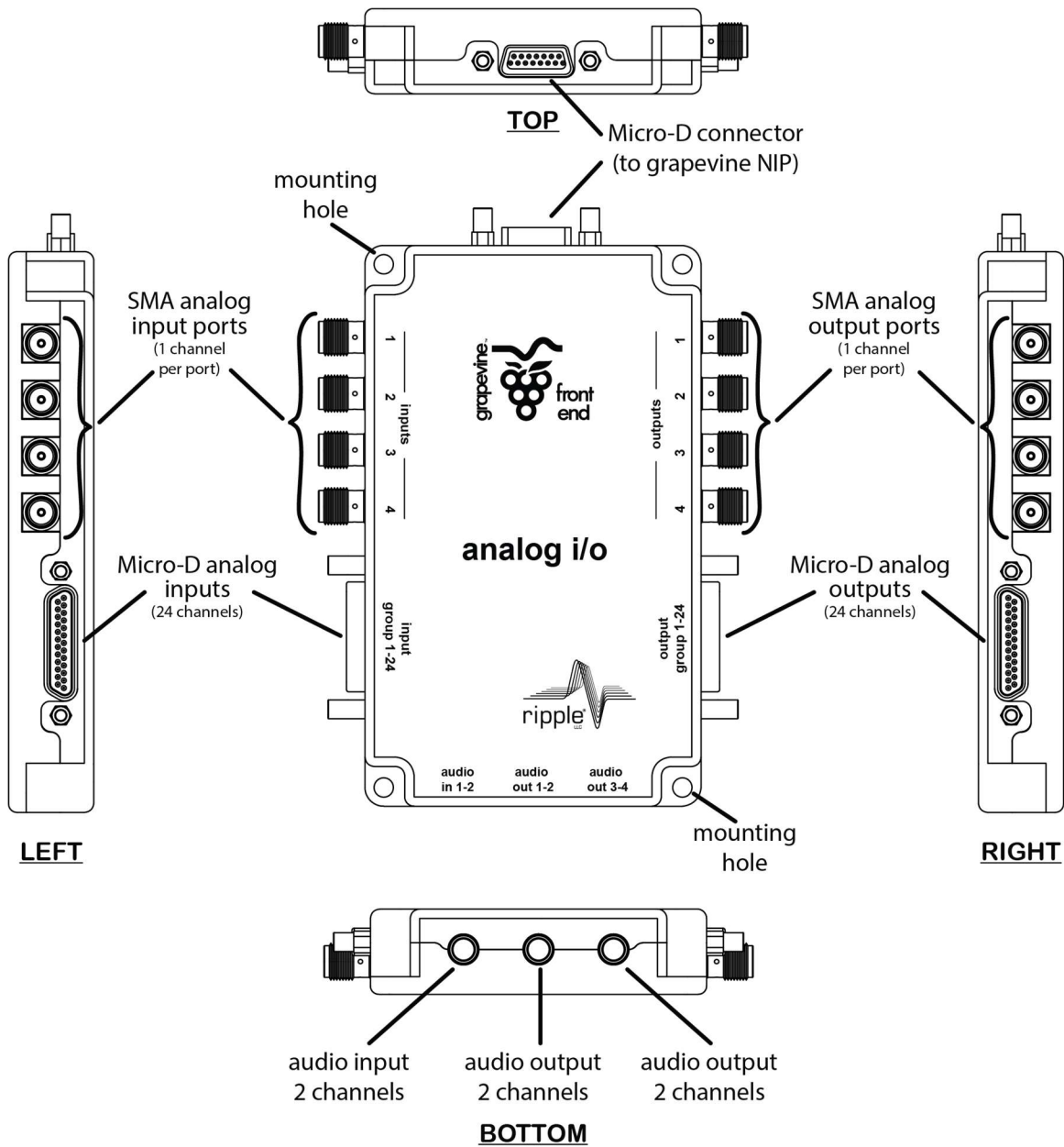

**Figure 1-12** Complete set of views for the Grapevine Analog I/O Front End (AIO)



## **Analog+Digital I/O**

The Grapevine Analog+Digital I/O Front End (ADIO for short) combines the capabilities of the AIO and DIO, enabling the Grapevine processor to interface with both analog and digital devices. All of the grounds on the ADIO are tied together internally to minimize grounding issues. The front panel contains markings and labels that identify the FE, as well as labels indicating the function of each port. The top panel of the ADIO provides the Micro-D connector used to connect the Front End to the processor, via a Front End I/O cable. The ADIO comes with two mounting holes that allow the device to be mounted to a wall or rack (using #4 screws, not included). For detailed specifications of the Grapevine Analog+Digital I/O Front End, see Appendix A.

### **Analog I/O Connectors**

The top half of the ADIO provides the inputs and outputs for analog signals with a  $\pm 5$  V range. Analog signals are synchronized with data recorded from other Grapevine FEs. The left side panel has 4 SMA analog input ports and the right side panel contains 4 SMA analog output ports. A signal acquired by any FE can be reproduced on any analog output channel, scalable up to  $\pm 5$  V. See the ‘Instruments > Analog Outputs’ section of Chapter 3 for detailed information on analog output routing of continuous data streams.

The bottom panel provides two 3.5 mm stereo audio jacks. The left jack is used for 2 channels of audio input that are acquired by the Grapevine processor, in sync with data being acquired from other Grapevine FEs. The right jack provides 2 channels of audio output. This allows for up to two channels of spiking activity to be played from attached speakers.

**Note:** The Analog+Digital I/O Front End does not include the Micro-D analog input and output connectors found in the Grapevine Analog I/O FE and does not support use with the Analog BNC Breakout adapter (PN: R01124).

### **Digital I/O Connectors**

The bottom half of the ADIO provides the inputs and outputs for interfacing with LVTTTL digital devices. The left side panel has 4 SMA digital input ports and the right side panel contains 4 SMA digital output ports. The front panel of the ADIO houses 2 Micro-D connectors, similarly to the DIO. The Digital I/O functions of the ADIO are the same as the DIO.

**Note:** Only one Analog+Digital I/O Front End can be connected to an NIP or Trek. The ADIO cannot be used with additional I/O FEs. The Scout Processor has built-in Analog I/O and Digital I/O Front Ends and cannot interact with an ADIO.

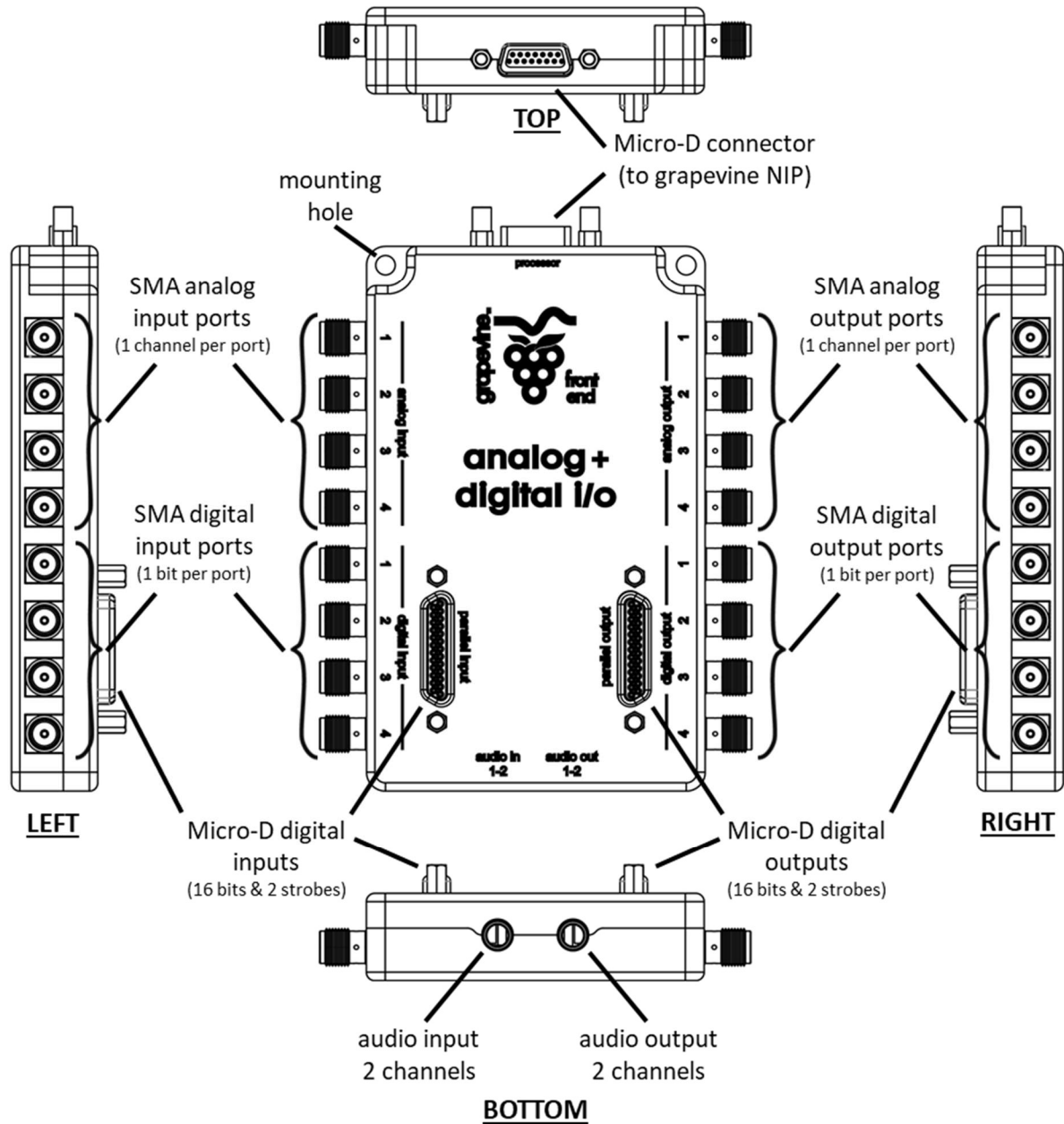

Figure 1-13 Complete set of views for the Grapevine Analog+Digital I/O Front End (ADIO)



## Scout Processor

The Grapevine Scout is a rack-mountable neural processor that is designed for lower-channel count, animal laboratory research applications. The system has built-in Analog I/O and Digital I/O Front Ends (FEs) and can be configured for up to 64 or up to 128 channels of data acquisition via up to two or four FEs. The operation of the Grapevine Scout system is the same as the Grapevine NIP.

**CAUTION: The Grapevine Scout is not intended for clinical or research use with humans. The Grapevine Scout is not CE approved.**

### Front Panel

The front panel of the Scout provides the power switch, Analog I/O and Digital I/O Front End connectors, and two Front End ports that can be connected to up to four FEs, depending on the Scout configuration. The Analog I/O and Digital I/O Front Ends that are built into the Scout are the same as the standalone versions described earlier, except that there are four BNC connectors for the first four channels of the FE instead of four SMA connectors, and the additional breakout channels use a standard 25-pin D-sub connector instead of a Micro-D connector.

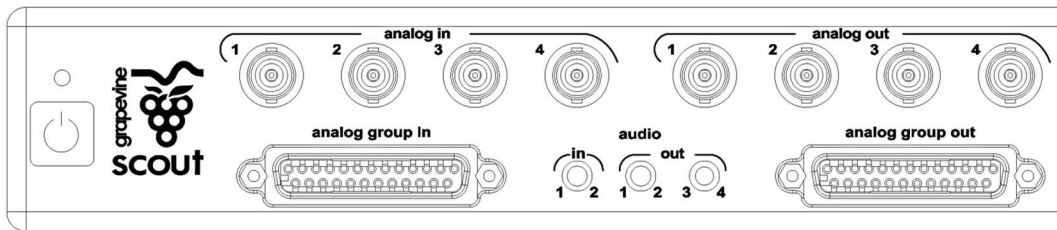

Figure 1-14 Front panel view of the Grapevine Scout (left side)

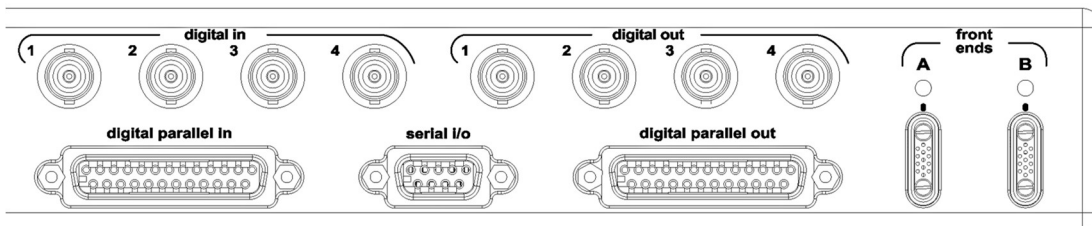

Figure 1-15 Front panel view of the Grapevine Scout (right side)

### Back Panel

The back panel of the Scout provides ports for interfacing the processor with computers over an Ethernet network, expansion ports, and auxiliary control interfaces, as well as the device serial number. For discussion on the expansion and auxiliary ports, please refer to the Grapevine NIP section. **Note:** The VGA plate on the back of the Scout processor should remain attached at all times as the VGA port beneath is for Ripple development and testing purposes only.

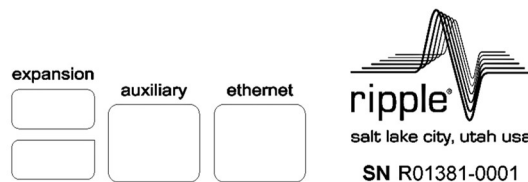

Figure 1-16 Back panel view of the Grapevine Scout



## Trek Processor

The Grapevine Trek is the smallest available neural interface system for stimulation and recording signals on up to 512 channels. With wireless data transmission and on-board battery and data storage features, this Grapevine processor is designed to be a portable platform for neuromodulation and brain machine interface experiments. This section describes the different connectors, indicators, and features of the Trek. Unlike the NIP and Scout processors, the Trek utilizes Onanon<sup>®</sup> connectors for front end cables and the power cable. These connectors easily slide into the port and are held in place by magnets.

**Note:** The Grapevine Trek is the successor to the legacy Grapevine Nomad.

**Note:** Type CF marked Front Ends are rated as Type BF when used with the Grapevine Trek.

### Front Panel

The front panel of the Trek provides labeling for the power button, critical status indicators, Front End port indicators, a button for stopping stimulation, and three programmable buttons and indicators for the optional “Code On the Box” functionality.

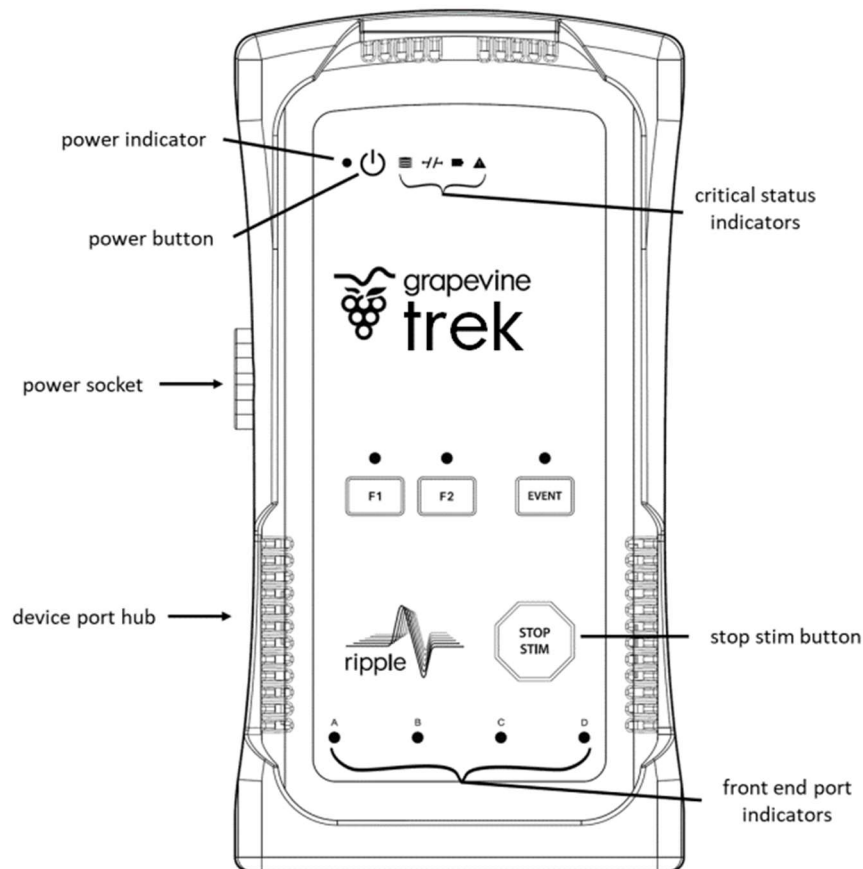
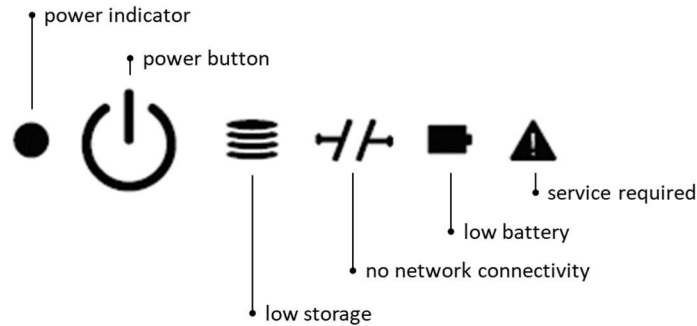

Figure 1-17 Front panel of the Grapevine Trek



**Figure 1-18** Front panel status indicators of the Grapevine Trek

### Power Button and Indicator LED

The power button, on the upper left of the front panel, toggles the power status of the Trek. When turning on the Trek, the power indicator LED will turn orange, indicating that the Trek is in startup mode. After a few seconds and an audible beep, this light will turn green to indicate that the Trek has initialized and is streaming data. When the Grapevine processor is not initialized, the power indicator will remain blue to show that the unit is in standby mode. To power off the Trek, hold the power button for approximately one second and the power indicator will turn off.

### Critical Status Indicators

Just to the right of the power button are four critical status indicators. From left to right, these indicators signify: 1. Low internal storage, 2. No network connectivity, 3. Low battery, 4. Service required: the device has shut down due to excess moisture and needs to be serviced by Ripple immediately.

**Note:** The service light is also used to indicate a firmware update is taking place, during which the light will pulse.

### Front End Port Indicators

The Front End port indicator LEDs will turn green when a Front End cable attached to a functioning FE is connected to a Front End port. These indicators perform the same functionally as those on the Grapevine NIP.

**Note:** All desired FEs must be connected to Front End ports before the Trek is powered on.

### Stop Stim Button

The red ‘Stop Stim’ button on the lower right of the front panel stops all existing stimulation commands. Stimulation commands instantiated after the button has been pressed are still allowed to proceed.



## Programmable Buttons and Indicators

The Trek features three programmable buttons for Code On the Box operations, labeled as ‘F1’, ‘F2’, and ‘EVENT’. For more information on button programming, see the Code On the Box manual.

### **Bottom Panel**

The bottom panel of the Trek houses four Onanon Front End ports to attach Grapevine FEs.

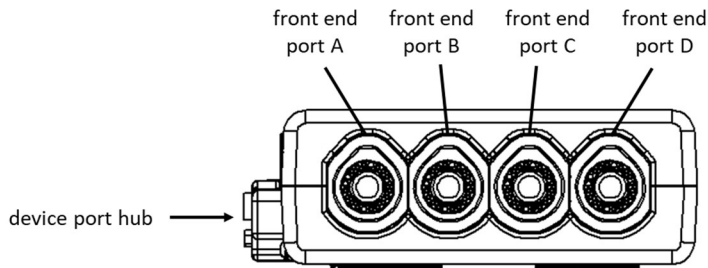

**Figure 1-19** Bottom panel of the Grapevine Trek

### Front End Ports

There are a total of four Front End ports that can each be connected to up to four Grapevine FEs via single, double, triple, or quadruple Front End cables. In total, the four ports enable the Trek to support up to sixteen Grapevine FEs.

**Note:** Only recording/stimulation FEs are supported via Onanon ports, not I/O FEs (such as the AIO, DIO, or ADIO) which utilize LEMO Front End connectors.

**Note:** Front End cables should be removed from the port by pulling on the connector housing only; do not pull on the cable.

### **Left Panel**

The left panel of the Trek provides terminals and ports for interfacing with a power supply, CAN bus, USB port, and I/O Front End modules.

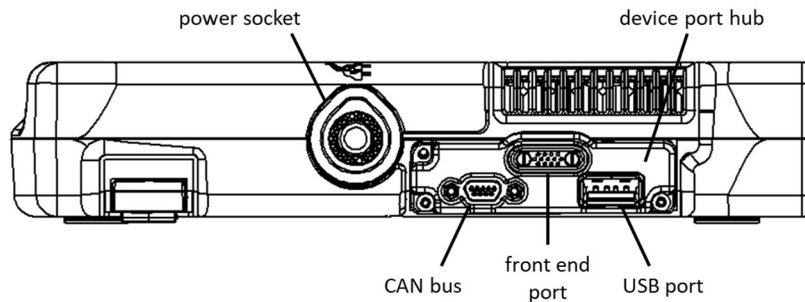

**Figure 1-20** Left panel of the Grapevine Trek





## Power and Ethernet Connection

The Trek uses an Onanon style power connector to connect to an isolated medical power supply that is provided with the processor. The IEC 60601-1 compliant power supply with mains isolation specifications uses a 3-pin IEC power socket to connect to a 3-pin earthed (grounded) power cable. The power supply can be used in all common international main power supplies, between 100-240 V AC at 50-60 Hz.

Additionally, the included power supply houses the Ethernet port. The Ethernet port connects the Trek to a computer, enabling the Trek to transmit data acquired from the FEs to Trellis. A network switch may also be used to enable control of a single Trek by multiple computers running Trellis software and/or other control software.

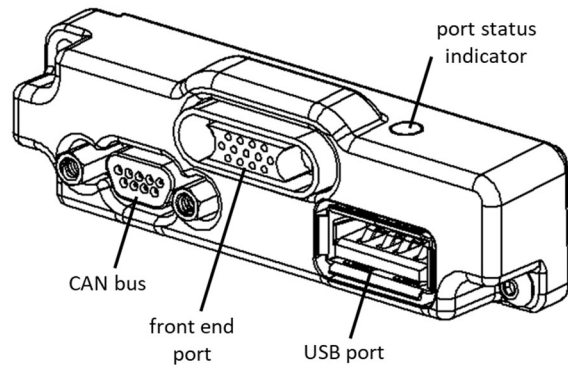

**Figure 1-21** Grapevine Trek Device Port Hub

### Device Port Hub

The Device Port Hub is an optional hardware component that houses a CAN interface port, a USB port, and a LEMO Front End port to be used with a Grapevine Digital I/O or Analog+Digital I/O Front End. The port status indicator LED is located on the front panel face of the Device Port Hub. The indicator turns green when the port is powered on and operational and red if there is a port error. Contact Ripple if you wish to implement the CAN interface port.

**WARNING: Due to power limitations, only devices that have been explicitly approved by Ripple can be safely connected to the Device Port Hub on the Grapevine Trek.**



### Right Panel

The right side panel of the Trek houses the device status indicators.

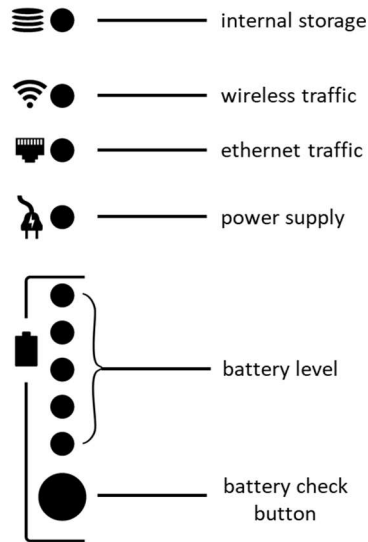

Figure 1-22 Status indicators on right panel of the Grapevine Trek

### Status Indicators

Table 1-5 Grapevine Trek Status Indicators

Status Indicator	Meaning
Internal storage	Internal storage capacity. The LED will be green to indicate storage is available, and yellow to indicate low storage.
Wireless traffic	Indicates data is streaming over the wireless network.
Ethernet traffic	Green LED indicates the Trek is sending data over the network for visualization and capture.
Power supply	Green LED indicates the Trek is drawing power from the power supply, even if the Trek is turned off.

### Battery Power Check Button

Pushing the button illuminates the current power level of the internal battery. If the Trek is plugged in, the battery status indicators will light automatically.



### **Back Panel**

The back panel of the Trek provides a port for interfacing the processor with an external battery as well as the device serial number.

#### **External Battery Port**

The external battery port is covered by a spring-loaded door to protect the electrical connector during normal operation. The optional external battery extends the life of the device from 1 hour up to 6-10 hours. Magnets on the bottom of the Trek aid in holding the external battery in place.

**Note:** When the external battery is attached and the Trek power supply is plugged in, the external battery will be charged before the internal battery.

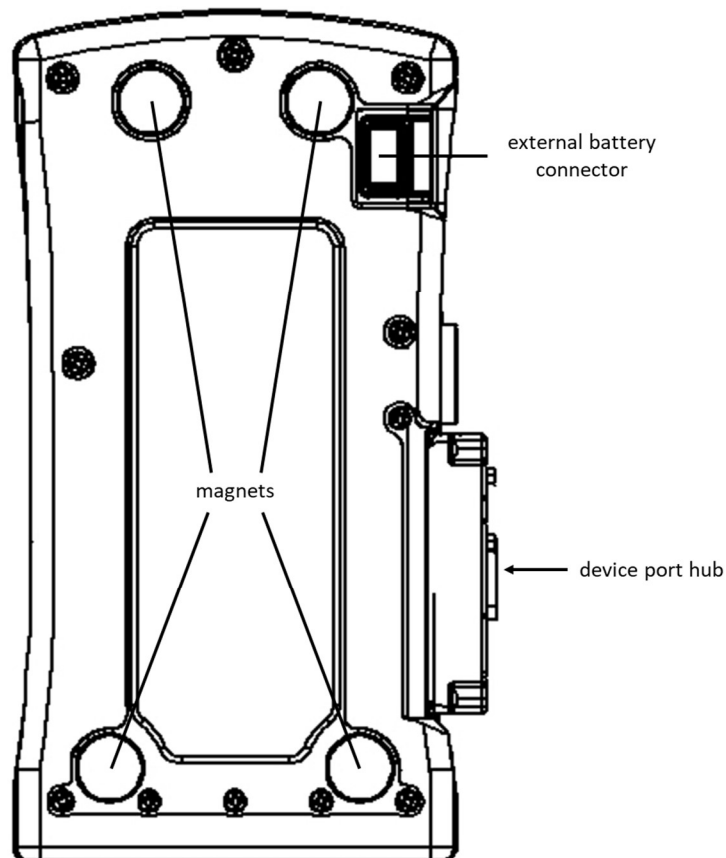

**Figure 1-23** Back panel of the Grapevine Trek

### **Additional Features**

Like all Grapevine systems, the Trek utilizes Ripple's Trellis software suite for data analysis and visualization, system configuration, and stimulation control. The Trek can be programmed to run custom code for real-time closed-loop applications in the absence of a host computer. For more information on this feature, please refer to the Code On the Box manual.



## Wireless Connectivity

To initially configure the Trek’s wireless features, physically connect the Trek to the host computer via the Ethernet port on the Trek’s power supply. The web interface for the Trek can be accessed by navigating a web browser to the URL: **192.168.42.1**

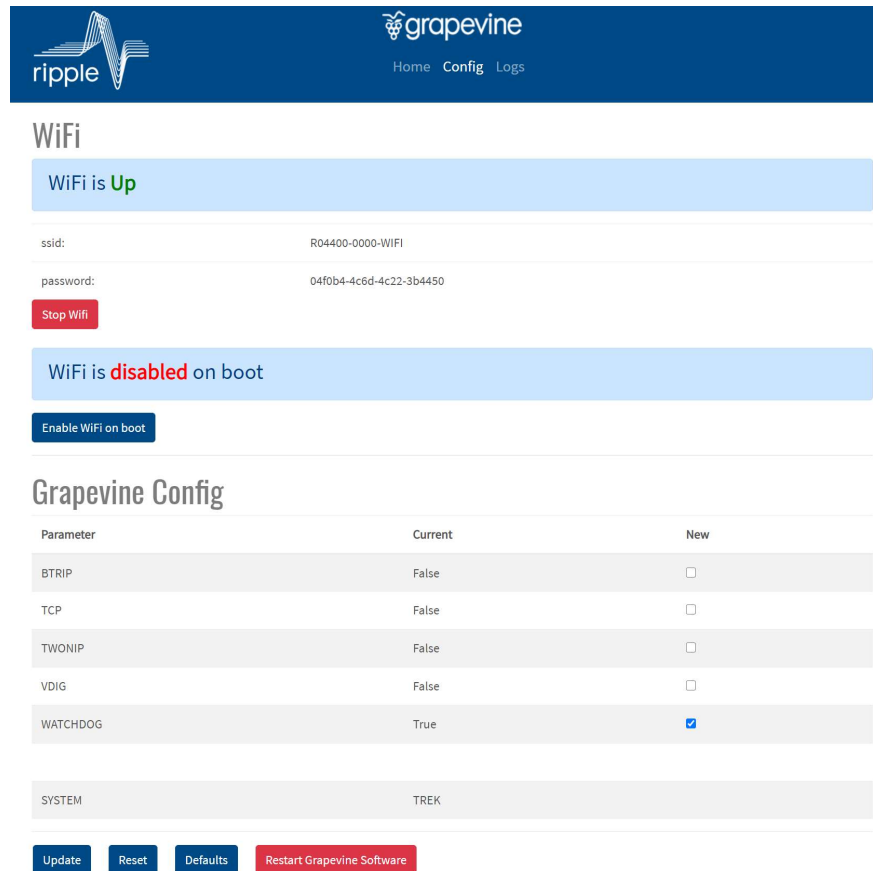

**Figure 1-24** Grapevine Trek Web Interface Config Tab

To enable wireless communication, click on the green button: ‘Start WiFi’. The wireless SSID and password of the Trek will be displayed on the page as illustrated in Figure 1-24. Direct the wireless network card to the SSID and enter the password to connect.

To enable wireless data streaming to Trellis, the Trek must be configured to run in TCP mode. This can be done from the web interface by clicking the checkbox for ‘TCP’ and then pressing the ‘Update’ button. The Trek must restart for this change to take effect. The Trek will assign the host machine an IP address (via DHCP). This address will then be visible in Trellis when the Network is set to ‘wireless’ and the Mode is set to ‘TCP’ (see Figure 3-4 for reference).

**Note:** When connected to the Trek through the wireless network card only, the web interface will be located at: **192.168.43.1**

**Note:** Currently the Trek wireless bandwidth does not support streaming raw signals on all 512 channels simultaneously.

# Installation and Setup



This chapter describes various options for connecting a Grapevine processor to one or more computers for visualizing and recording data.

## Connecting the Hardware

The Grapevine processor must be connected via a Gigabit Ethernet connection to computers running the Trellis software suite. This can be accomplished either through a direct connection to a low-latency 1 Gb network interface card or through a low-latency 1 Gb network switch. Ripple recommends that Windows users contact the computer manufacturer (Dell, Lenovo, etc.) to determine which network interface card or Ethernet adapter is best suited for their system. The NETGEAR® GS105 network switch is recommended by Ripple for multiple computer configurations.

### Direct Connection to Computer

Use a gigabit Ethernet cable to connect the Ethernet port of the Grapevine processor (labeled “eth” or “Ethernet”) to a dedicated Network Interface Card (NIC) in the host computer. Use the following sections to configure the computer’s NIC for communication with the Grapevine processor. Each Grapevine processor has a static IP address of 192.168.42.1. The operating system’s network configuration needs to be set up on the same subnet as the Grapevine processor to enable data communication (192.168.42.x, where x is in the subnet range of 129-254).

### Multiple Computer Connections to the Processor

Multiple computers can be connected to a single processor through the use of a gigabit Ethernet switch such as the NETGEAR GS105. Each additional PC must also have an Ethernet connection that belongs to the instrument subnet. The IP addresses for these computers should be incrementally numbered: 192.168.42.129, 192.168.42.130, etc., up to 192.168.42.254.

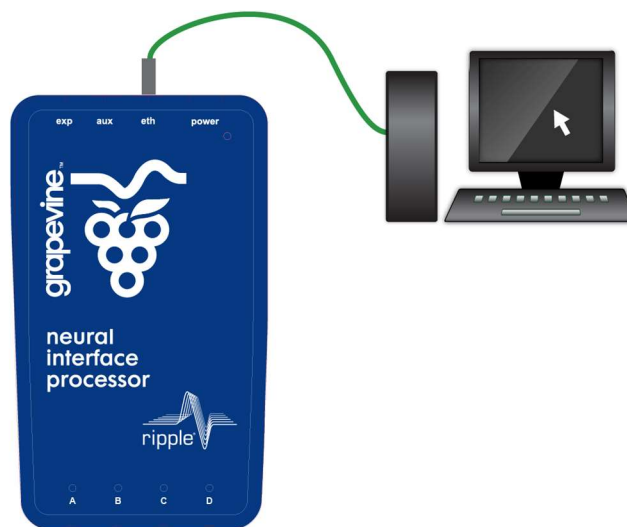

**Figure 2-1** Connecting a Grapevine NIP to a computer with an Ethernet cable



## Windows 7 Network Configuration

Configuring the Grapevine processor to work with a Windows 7 computer can be done completely through the Windows 7 Control Panel. The two main processes include configuring the Grapevine's Network Interface Card to the proper IP address and configuring the firewall. **Note:** This configuration process is similar for Windows 10 operating systems.

Configuring the Network Interface Card connected to the Grapevine processor

### *Step 1 – Open Control Panel*

Click on the Windows button and then “Control Panel” to open the Windows 7 Control Panel.

**Note:** The following steps in this manual are written when viewing the control panel by large icons.

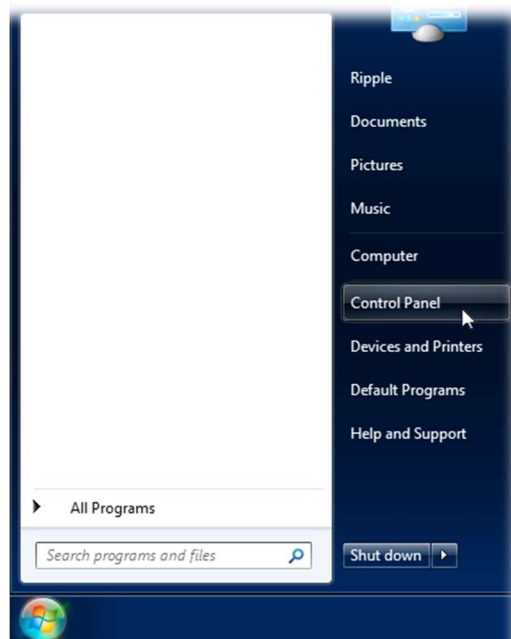

**Figure 2-2** Step 1 – Open the Control Panel

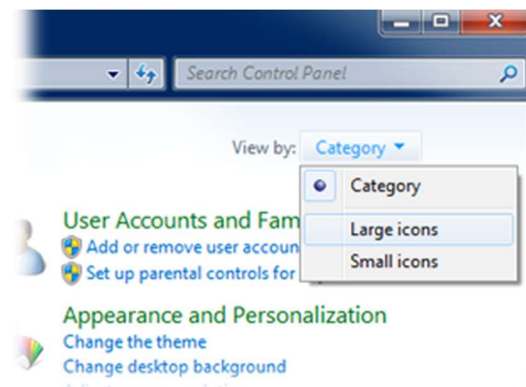

**Figure 2-3** Step 1 Note – View the Control Panel by Large icons



### Step 2 – Open Network and Sharing Center

Click on the “Network and Sharing Center” icon to access the network settings.

### Step 3 – Open Network Interface Card List

Click on “Change Adapter Settings” on the left side of the Network and Sharing Center panel.

### Step 4 – Open the Network Adapter’s Properties

Identify which of the network cards on the list is used to connect to the Grapevine processor. It may help to rename this network card to “Grapevine NIC” for clarity in the future, as changing the properties on this network card may make the Grapevine processor no longer function properly. Right click on the appropriate Network Adapter and select “Rename...” to rename the network card.

### Step 5 – Configure the Network Adapter’s Properties

Right click on the card again and select “Properties” from the list. Uncheck all of the boxes except for “Internet Protocol Version 4 (TCP/IPv4)”. Then, select “Internet Protocol Version 4 (TCP/IPv4)” from the list and click the “Properties” button on the right side of the pane. Change the settings as shown in Figure 2-4 below, with the IP address set to **192.168.42.129**, subnet mask set to 255.255.255.0, and the gateway blank. When these settings are entered, click OK to apply them and close this window. Also, click OK on the Network Interface Card’s Properties window to apply the settings and close the window.

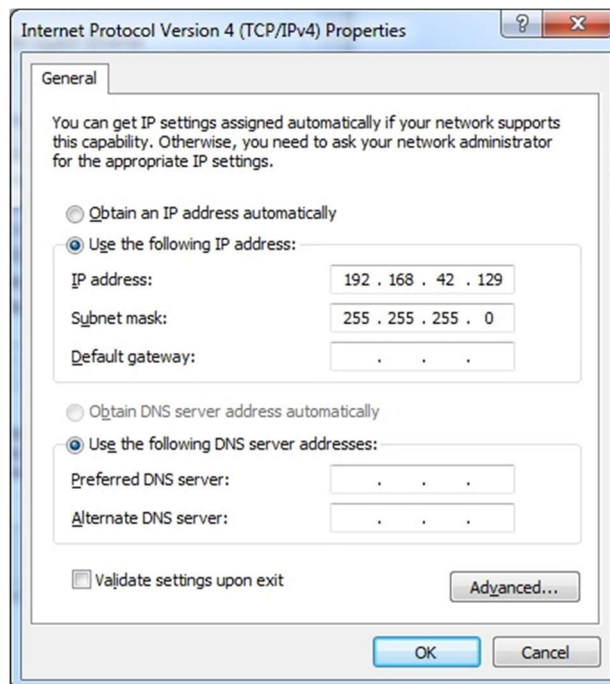

Figure 2-4 Step 5 – Correct network adapter settings for IPv4

The computer will be able to receive data from the Grapevine processor with this configuration. However, firewalls and other network security settings may interfere with the communication, resulting in an inability to collect data or possible data loss. To ensure that the system functions properly, disable all firewalls and network security involving the network card connected to the Grapevine processor.



## Disabling the Windows Firewall

### *Step 1 – Open Control Panel*

Click on the Windows button and then “Control Panel” to open the Windows 7 Control Panel.

### *Step 2 – Open Windows Firewall Settings*

Viewing by Large Icons, click on “Windows Firewall” to access the Firewall settings.

### *Step 3 – Open Advanced Firewall Settings*

Click on “Advanced Settings” on the left side of the Windows Firewall panel.

### *Step 4 – Open Windows Firewall Properties*

Click on “Windows Firewall Properties” in the middle of the Windows Firewall with Advanced Security window. In this window, each of the profiles must be changed to enable data streaming over the network to and from the Grapevine processor. These are configured in each of the tabs listed in the window including the Domain Profile, Private Profile, and Public Profile.

### *Step 5 – Configure the Domain, Private, and Public Profile*

In the “Domain Profile” tab, click on the “Customize” button next to the label that reads “Protected Network Connections”. In the window that appears, uncheck the NIC to which the Grapevine processor is connected. Click OK to exit this window and apply the settings. Repeat this step for both the “Private Profile” tab and the “Public Profile” tab. Click on the OK button of the Windows Firewall Properties window to apply all of the settings. After completing Step 5, the Windows Firewall will be disabled for the network card that connects the computer to the processor.

Third party antivirus software such as Norton Antivirus and McAfee Antivirus may contain firewalls that can interfere with the communication with the Grapevine processor. These should also be disabled. Also, virus scanners should be disabled when recording data.

## **Mac OS X Network Configuration**

Configuring the Grapevine processor to work with a Mac computer running OS X can be done completely through the System Preferences’ Network Panel; no firewall settings need to be changed.

### Configuring the Network Interface Card connected to the Grapevine processor

#### *Step 1 – Open System Preferences*

Click on the Apple icon in the top left hand side of the screen, and then “System Preferences...” to open the Mac OS X System Preferences window.

#### *Step 2 – Open the Network panel*

Click on the “Network” icon listed under the “Internet & Wireless” section of the System Preferences window.

#### *Step 3 – Select the Network Interface Card connected to the Grapevine processor*

On the left side of the Network window, there is a list of the available network interfaces that exist on the Mac computer. The Grapevine processor will be connected to one labeled “Ethernet” or “Ethernet Adaptor”, depending on the computer. Click on the network interface that is connected to the NIP to show its settings. These settings will appear on the right side of the window.





#### Step 4 – Configure the Network Interface Card connected to the Grapevine processor

First, click the dropdown to change the “Configure IPv4” field to “Manually”. This should allow for changes to the “IP Address” field. In the “IP Address” field, enter the value of **192.168.42.129** with a subnet mask of **255.255.255.0**. Leave the rest of the fields blank.

#### Step 5 – Configure the necessary Advanced Settings

In the Network panel, select the appropriate Network Interface Card, click on the “Advanced...” button in the bottom right of the screen to access the advanced settings. Click on the “Ethernet” tab and change the values as follows:

- Configure: Manually
- Speed: 1000baseT
- Duplex: full-duplex
- MTU: Standard (1500)

Additional third-party firewall programs, such as Little Snitch, should be disabled.

**Note:** Users of Mac OSX 10.9 and above should disable App Nap globally. This can be done by opening a Terminal from the ‘\Applications\Utilities’ directory and entering the command below. Be sure to restart the computer after running the command. ([reference](#))

- `defaults write NSGlobalDomain NSAppSleepDisabled -bool YES`

## Linux Network Configuration

The exact method to set up the network for the Grapevine processor varies based on the Linux distribution that is running. Below are the settings that must be established, through either the appropriate setup tool or command line. For Ubuntu 12.04, the Network Connections interface can be opened by entering `nm-connection-editor` in a terminal window. This will open a graphical interface similar to Figure 2-5, where the network settings can be configured.

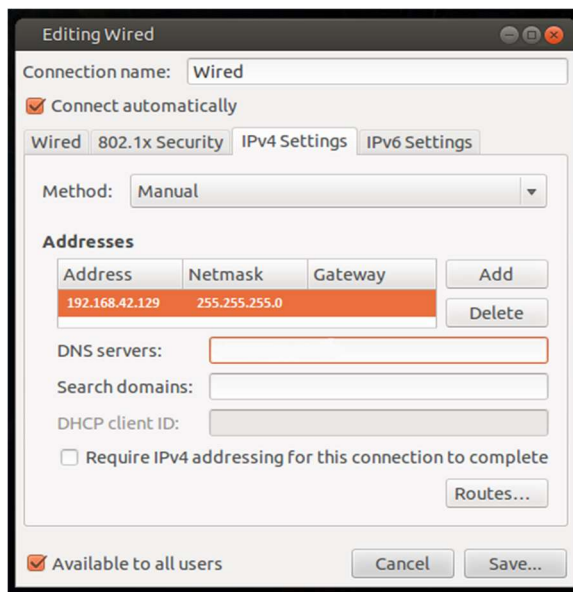

- DHCP Configuration: Static or Manual
- IP Address: 192.168.42.129
- Netmask: 255.255.255.0
- Speed: 1000baseT
- Duplex: full-duplex
- MTU: Standard (1500)

Figure 2-5 Correct network adapter settings for IPv4 Settings

# Trellis Software Suite



The Trellis software suite consists of a main program (Trellis) responsible for managing the instrument network and recording data to disk, and a set of applications (Raster, Spike Scope, Spike Grid, Impedance Analyzer, and Stimulation Controller) that provide the ability to visualize signals, configure spike extraction and sorting, measure electrode impedance, and control stimulation. The Trellis software suite installer for a chosen operating system can be downloaded from the [Ripple website](#). Check the Ripple website for software patches and new releases.

To install the Trellis software suite, simply execute the installer and follow the prompts. A computer restart is recommended after following the installation process. Trellis is supported for Microsoft Windows (7, 10), Mac OSX (10.7-10.13), and Linux (tested with Ubuntu 16.04).

**Note:** Updates to the Trellis software suite often require a complimentary software update to the Grapevine processor. Contact Ripple Support before downloading and installing any Trellis software updates.

## Using Trellis Software

Before running Trellis, ensure that all Front Ends are connected to Front End cables, all cables are connected to the Grapevine processor, that the processor is turned on (green LED indicator), and that it is connected to the computer. To run Trellis on Windows, double click on the application link that was placed on the computer desktop during installation. On Mac, navigate to the Trellis subfolder of the Applications folder and click on the Trellis.app icon. On Linux, Trellis can be found in Gnome's list of installed applications.



**Figure 3-1** Trellis desktop icon (Windows)

The main Trellis program presents three tabs on the left side of the window (Instruments, Applications, and File Save) that provide access to different aspects of program functionality. The color scheme for Trellis and which messages are displayed can be set from the Trellis Settings window, as shown in Figure 3-2. These options can be accessed from the Tools menu or from the Settings icon located at the top right of the Instrument Configuration panel shown in Figure 3-7.

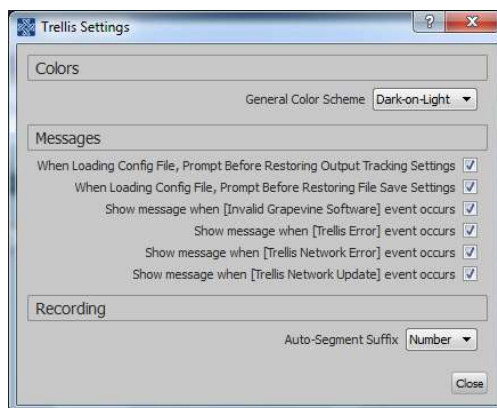

**Figure 3-2** Trellis Settings window



## Instruments

The Instruments tab contains general information about the instrument network and detailed information about individual Grapevine processors and Front Ends. When Trellis is started, the Instrument Network will display the Network Info panel, similar to Figure 3-3. This view displays network status, a plot of aggregate network load, and details on the composition of network traffic. If the data rate is too high for the computer to keep up, a warning message will be displayed when network data packets are lost.

All available Front Ends and data streams will be listed under their associated Grapevine processor in the Instrument Network tree on the left side of the window. Some configuration options are detailed below:

- User-controlled parameters for specific Front Ends can be set by selecting a Front End entity, as shown in Figure 3-5.
- Specific data streams can be configured for each Front End by expanding the Data Streams tree, and individual electrode channels can be initialized for spike or stim data streams where appropriate.
- Information about a Grapevine system can be accessed by selecting the corresponding entity in the Instrument Network. Selecting the “Grapevine NIP(1)” item in the Instrument Network brings up an interface to configure the Grapevine NIP, as shown in Figure 3-7.
- Electrode-to-channel map files can be loaded as shown in Figure 3-9.

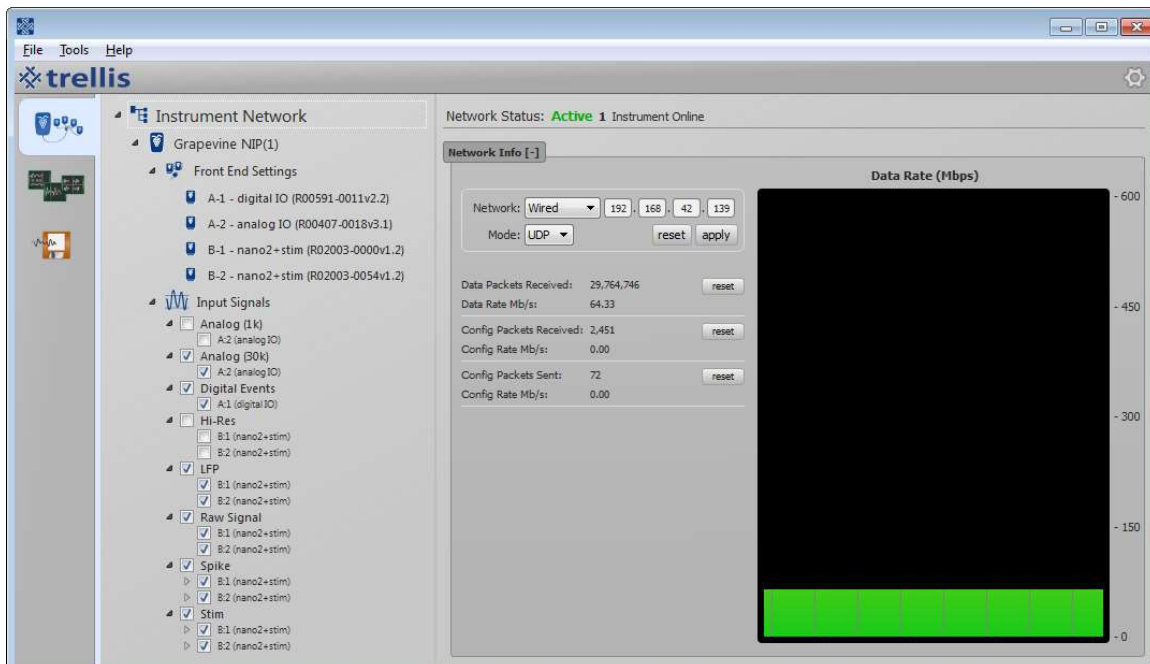

Figure 3-3 Trellis Instruments – Instrument Network

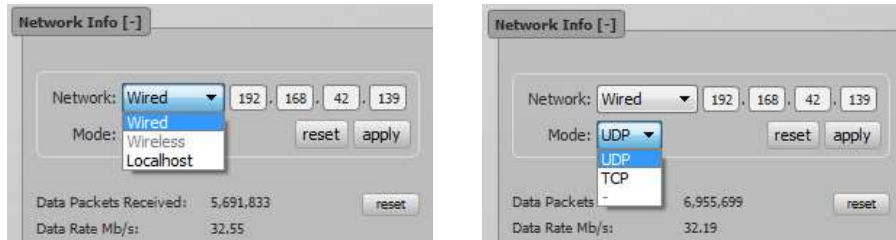

Figure 3-4 Expanded Network and Mode menus

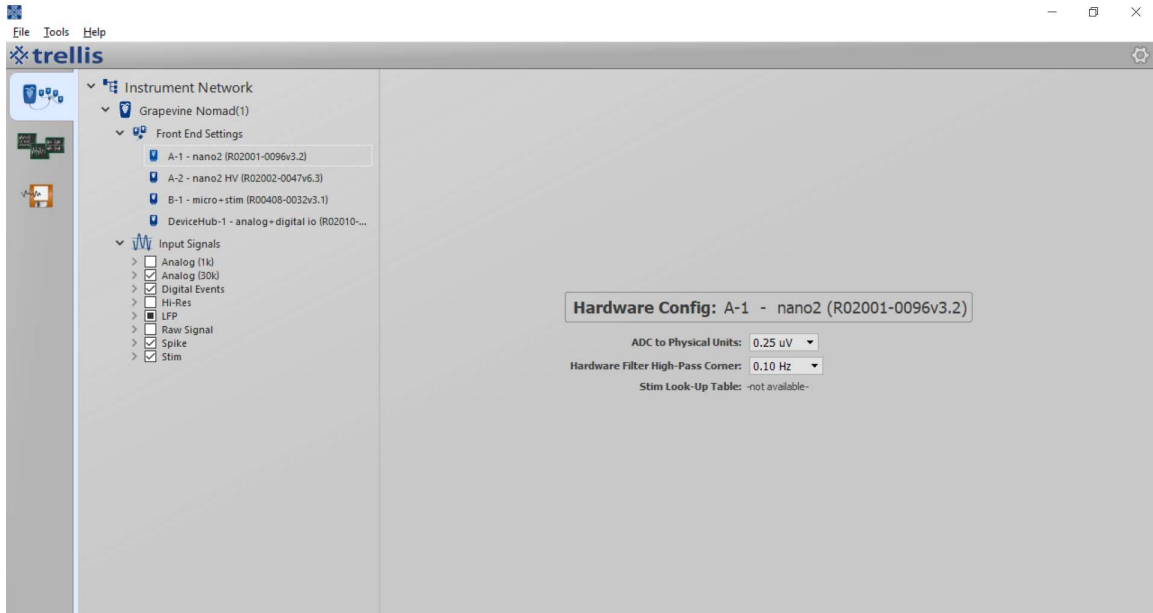

Figure 3-5 Trellis Instruments – Front End user-controlled settings

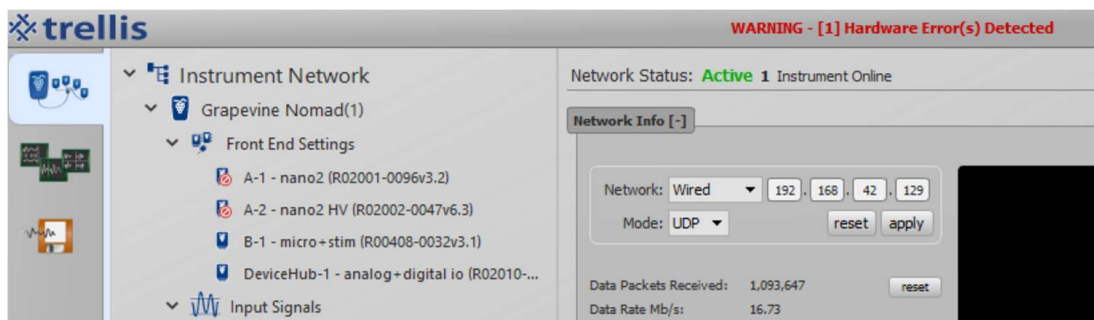

Figure 3-6 Trellis Instruments – Front End error

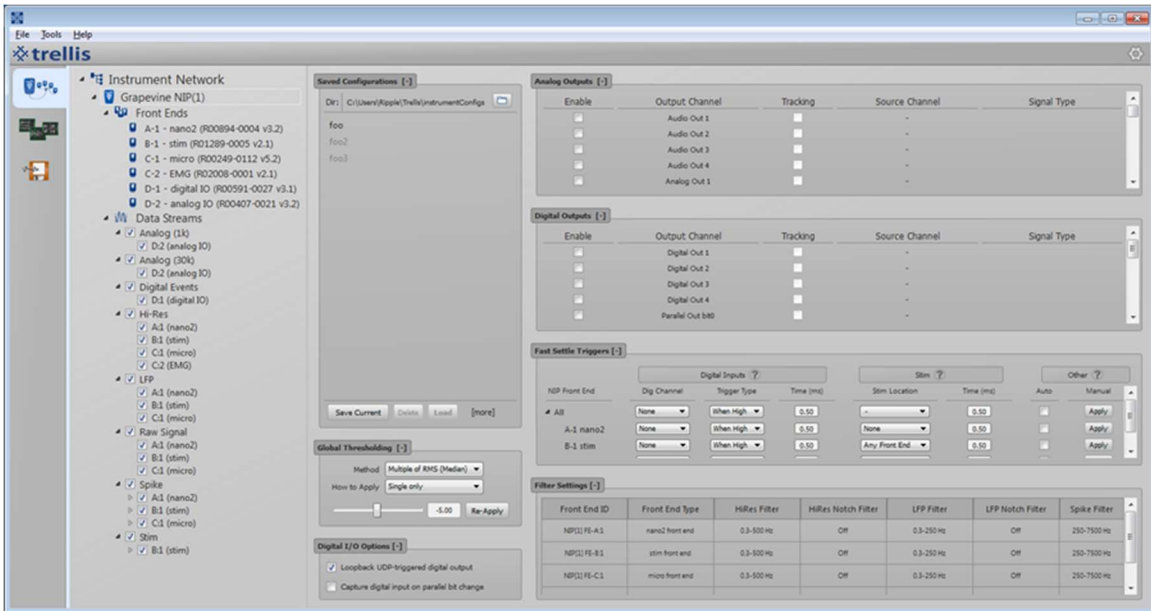

Figure 3-7 Trellis Instruments – Grapevine system configuration

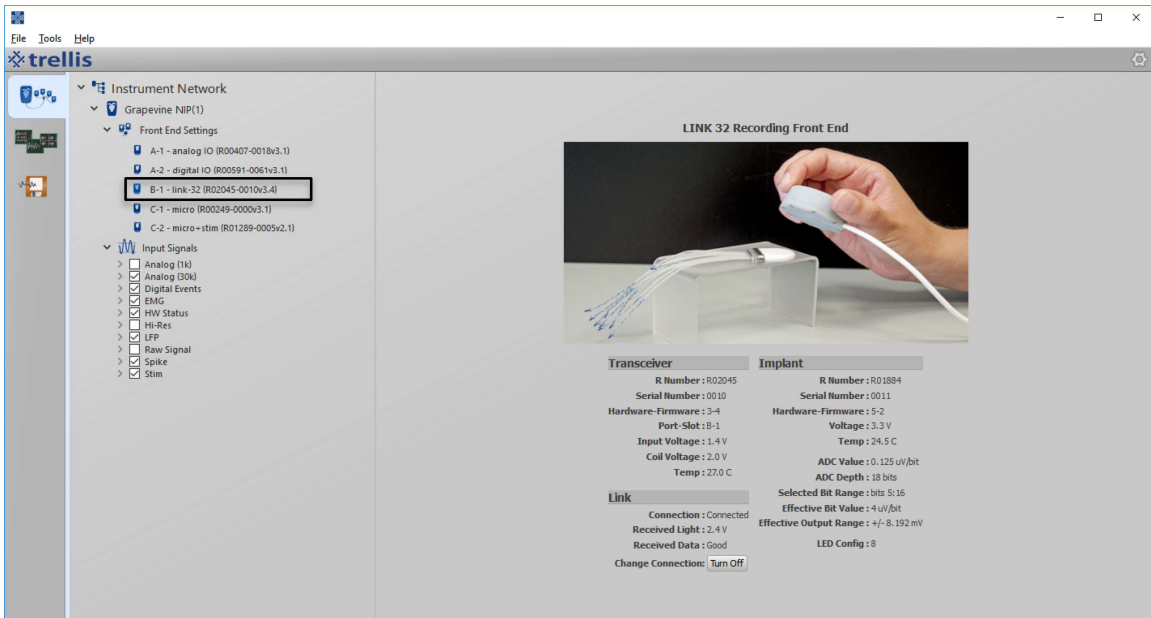

Figure 3-8 Trellis Instruments – Implantable Front End Information

Hardware information for Link style Front Ends can be found by clicking on the Front End entity similar to that shown in Figure 3-5. On this page the transceiver can be turned on and off to pair with the implant.



## Network Info

The Network dropdown menu (Figure 3-4, left) default option is Wired, for a wired data connection to the host computer. There is a Wireless option for the Trek and any future wireless enabled Grapevine processors. The following four fields show the host computer’s IP address in the Grapevine network.

The Mode dropdown menu (Figure 3-4, right) provides two options for the network protocol used for communication between the computer and Trellis. UDP protocol is the default option which broadcasts all data to each computer on the network. Packet drops can occur, sometimes excessively, in noisy environments or when using older computer hardware with poor graphics or CPU performance. In such cases, the second option, TCP protocol, will often alleviate the instance of dropped packets.

If TCP protocol is desired, contact Ripple support to enable that feature on the processor. After the processor has been correctly configured, select TCP then press the apply button. There are some system configurations in which TCP may not be the best solution.

## Electrode-Channel Map Files

Map files allows you to label and arrange channels to match the physical layout of your electrode array. Each map files contain a set of entries, one entry per line. Each line specifies a label and a display location (i.e. x, y) for a Front End channel. Once you load a map, all applications will update to use the specified labels. Also, Spike Grid will update to arrange spike displays according to the specified coordinates. Map files can be loaded from the Instrument Network browser by right clicking on a Grapevine system, e.g., Grapevine NIP(1), as shown in Figure 3-9 below, and clicking on “Load Channel Map”. Map files can be cleared by right clicking on the same Grapevine item and clicking “Clear Channel Map”.

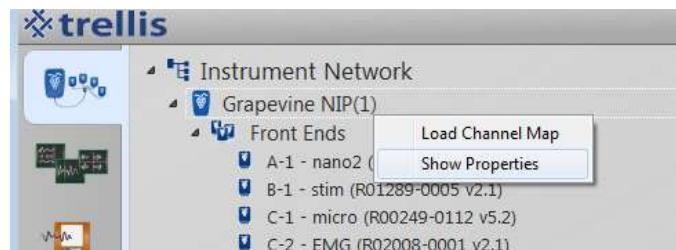

Figure 3-9 Trellis Instruments – Loading a global channel map



Electrode map files use a simple ASCII text-based format as follows:

```
# -----  
# Trellis standard electrode map file format:  
# <hardware.address>; <elec_group.elec_label>; <view.coords>  
#  
# Example: (for use with Grapevine processor)  
# -----  
# [processor.]port.FEslot.channel; [array.]electrode; [x.y.z]  
# (NOTE: all fields are 1-indexed)  
# -----  
1.A.1.020; USEA1.elec001; 1.1  
1.A.1.022; USEA1.elec002; 2.1  
1.A.1.024; USEA1.elec003; 3.1  
1.A.1.028; USEA1.elec004; 4.1
```

Each line specifies three values:

1. A hardware address
2. An electrode label
3. A grid position

Values in each row must be separated by semicolons. Rows can be specified in any order. The hardware address for a channel consists of the NIP ID (optional), port (A-D), FE slot (1-4), and channel number (1-32), separated by periods. The electrode label can be any arbitrary text string up to 10 characters in length. If multiple groups of electrodes are present (e.g. multiple physical arrays) an optional group label can be prepended to the electrode label, separated by a period. The view position for Spike Grid is a set of x.y.z coordinates separated by periods, where the 1,1,1 position is the top left corner of the Spike Grid display. An example map file can be downloaded from [here](#).

## Instrument Configuration

Trellis automatically detects which Front Ends (FEs) are connected to the Grapevine processor and displays the appropriate configuration panels, as shown in Figure 3-7. Each configuration panel can be expanded or collapsed by clicking the [+] or [-] symbol to the right of the panel title.

- **Data Streams.** This panel provides the ability to enable/disable the various data streams associated with each FE that is connected to the Grapevine processor. Each data stream consists of a series of data packets that are broadcast by the processor onto the instrument network (via UDP or TCP). The data streams and their properties are:
  - **Analog Input** streams can be enabled for the Analog I/O Front End at 1 kS/s per channel [Analog (1k)] and/or 30 kS/s per channel [Analog (30k)].
  - **Digital Input** streams can be enabled for the Digital I/O Front End at 10 kS/s by selecting the ‘Digital Events’ data stream.
  - **EMG** streams are unique to the Link family of implantable FEs. The EMG signals are sampled at 2 kS/s and are digitally filtered using a low pass IIR filter of 500 Hz (default).
  - **Hi-Res** streams contain continuous waveform data with 24-bit floating point precision allowing for better precision at the low end of the spectrum and wider



dynamic range, which can be useful for ECoG and EMG data. The Hi-Res signals are sampled at 2 kS/s and are digitally filtered using a low pass IIR filter of 500 Hz (default) with 4<sup>th</sup> order Butterworth characteristics.

- **HiFreq** streams can be enabled for EMG Front Ends and contain continuous waveform data with 24-bit floating point precision allowing for better precision and wider dynamic range. The HiFreq signals are sampled at 7.5 kS/s and are digitally filtered using a low pass IIR filter of 2000 Hz (default) with 4<sup>th</sup> order Butterworth characteristics.
- **HW Status** streams are unique to the Link family of implantable FEs. This stream includes various implant status variables sampled at 2 kS/s.
- **LFP** streams contain continuous waveform data for low frequency signals such as LFP, ECoG, EEG, and EMG. The LFP signals are sampled at 1 kS/s per channel and are digitally filtered using a low pass IIR filter of 250 Hz (default) with 4<sup>th</sup> order Butterworth characteristics.
- **Raw Signal** streams contain continuous waveform data with the entire bandwidth of the FE amplifier. The raw signal is sampled at 30 kS/s per channel.
- **Spike** streams contain neural events that cross the user-defined threshold for a channel. Each spike data packet consists of 52 samples captured at 30 kS/s (1.7 ms) and are digitally filtered with a high pass filter of 250 Hz (default). Spikes are aligned to threshold crossing, with 15 pre-threshold samples included in the waveform. **Note:** Spike events occurring faster than every 1.7 ms will not be completely captured as Spike event data packets do not overlap.
- **Stim** streams contain the voltage waveforms supplied by Stim FEs during stimulation, captured at 30 kS/s in 52-sample data packets.

**Note:** The Hi-Res and HiFreq data streams are the only options available for the EMG FE. The EMG and HW Status data streams are the only options available for the Link 32 FE.

- **Saved Configurations.** This panel provides the ability to save and load instrument configurations. Each configuration file saves the settings for data stream initialization, Front End outputs, fast settle triggers, filter specifications, and per-electrode data streams for file saving. The Grapevine system configuration may be saved at any point by clicking the ‘Save Current’ button. Alternatively, Trellis can be configured to periodically autosave the instrument configuration (click on the ‘more’ link to access this option). This panel also displays a list of previously saved configuration files. A saved configuration can be applied to an instrument by selecting the configuration from the list and clicking the ‘Load’ button. If the configuration is loaded successfully the text “load successful” will appear to the right of the item in the list. Only saved configurations that match the hardware currently connected to the Grapevine processor can be loaded, and inappropriate configurations will be grayed out. Front End information about each configuration file can be viewed by hovering the cursor over the file name.
- **Global Auto Thresholding.** This panel contains options for setting system-wide spike thresholds. The first dropdown specifies how the threshold is determined. The second dropdown specifies how the threshold is applied. Following is a description of the program behavior for various threshold algorithms when the “Single only” option is selected:
  - **Absolute Level (µV)** – Sets the threshold to the specified value. If a channel has dual thresholds set, the threshold is changed to a single positive or negative value based on the sign of the specified value.





- **Multiple of RMS** – Computes the threshold as the specified multiple of the running RMS estimate of the spike-bandwidth signal. The running estimate of the mean squared values has a first order time constant of approximately 2 seconds and settles in 4 to 6 seconds. As a direct RMS estimate, it can be biased by spikes and strong transients in the signal. If a channel has dual thresholds set, the threshold is changed to a single positive or negative value specified by the sign of the multiplier.
- **Multiple of RMS (Median)** [default] – Computes the threshold as the specified multiple of the running median estimate of the spike-bandwidth signal or Median Absolute Deviation (MAD). The MAD calculation algorithm settles in approximately 5 to 10 seconds, and it is scaled by 1.482 so that the result approximates the RMS multiplier method for Gaussian noise. If a channel has dual thresholds set, the threshold is changed to a single positive or negative value specified by the sign of the multiplier.
- **Digital I/O Options.** This panel enables two features for the Digital I/O Front End:
  - **Loopback UDP-triggered digital output** – Enabling this checkbox configures the Grapevine processor to echo, back onto the instrument network, all Digital I/O outputs that are emitted in response to requests by other entities on the instrument network. This option must be enabled to run the network latency test.
  - **Capture digital input on parallel bit change** – By default, the state of the 16-bit parallel port on the Digital I/O Front End is only captured when either the Strobe A or Strobe B port is set high. This checkbox enables capture of the 16-bit parallel port state when there is a bit change on any of the parallel port lines.
- **Analog Outputs.** This panel enables routing of selected neural data (Raw, LFP, Hi-Res, or Spike Filtered) to the Analog I/O output ports. The analog output gain is 1000x for the Raw data stream (1 mV input = 1 V output), 5000x for the LFP and Spike Filtered data streams (1 mV input = 5 V output), and 250x for the Hi-Res data stream (allows for full range of EMG Front End). **Note:** The analog audio output gain is 500x for Raw data streams (1 mV input = 0.5 V output) and 2500x for the LFP, Hi-Res, and Spike Filtered data streams (1mV input = 2.5 V output). The output data is digitized at 30 kS/s and there is a fixed delay of 5 ms for 30 kS/s Raw data, 6 ms for 2 kS/s Hi-Res data, and 7.5 ms for 1 kS/s LFP data. When tracking is enabled, the Analog I/O output port will adjust and follow the active channel that has focus. **Note:** Only Spike Filtered data is routed to the selected Analog I/O output port when tracking is enabled.
- **Digital Outputs.** This panel enables the Digital I/O Front End output ports (SMA 1-4 and parallel 1-16) to emit a 1.7-ms LVTTTL pulse, when specified conditions occur on a selected neural channel. When tracking is enabled, the port will adjust and follow the active channel that that has focus. The exact latency from a spike or stimulation event to the digital output pulse is 6.2 ms from the spike threshold-crossing event or 5 ms from the stimulation event.
- **Fast Settle Triggers.** This panel contains options for configuring the triggers for fast settling of recording FEs. This is useful for simultaneous stimulation and recording applications that can have a stimulation artifact in the recording. All FEs can be configured together, or each one can have a unique trigger set by expanding the ‘All’ selection under ‘NIP Front End’. There are four ways to apply FE fast settling as described below, and clicking the question mark next to each trigger type will bring up help information. **Note:** Fast settle is not available on Grapevine Nano (v1) FEs older than firmware 2.2.



- **Digital Input Triggers** – Use an external digital input connected to one of the four SMA input ports on the Digital I/O FE. The trigger can be set to when the signal is high or low. Each FE will have fast settling enabled for the duration of the digital input trigger and for the specified duration after the digital input trigger.
- **Stim Triggers** – Use a stimulation pulse from a stimulation FE connected to the Grapevine processor. The fast settling of each FE will occur during the stimulation pulse and for the specified duration afterwards. The stimulation trigger can occur on the:
  - **Any Front End** – A stimulation pulse on a Stim FE will trigger fast settling of all recording channels on all supported FEs.
  - **Same Front Port** – A stimulation pulse on a Stim FE will trigger fast settling of all recording channels on all supported FEs connected to the same Front End port as the Stim FE.
  - **Same Front End** – A stimulation pulse on a Stim FE will trigger fast settling of all recording channels on only the Stim FE that produced the stimulation.
- **Auto Trigger** – All channels for a Front End will automatically be fast settled if any one channel reaches saturation. The duration of the auto trigger fast settle is specified by the digital input trigger time. **Note:** If this option is enabled in a situation where one or more channels on a Front End frequently saturates (e.g., if a channel is disconnected), the recordings on the good channels will likely be compromised due to frequent triggering of the fast settling behavior.
- **Manual Trigger** – Click this button to fast settle all channels of a Front End. The duration of the manual trigger fast settle is specified by the digital input trigger time.
- **Filter Settings.** This panel provides the FE digital signal processing filter settings for all appropriate FEs. Each FE is noted by its Front End ID. The specific cutoff frequencies for each filter type can be changed by double clicking on the values, as shown in Figure 3-10. Filter characteristics can be set for all FEs by clicking on the filter type, e.g., ‘HiRes Filter’. These digital filters are IIR filters with 4<sup>th</sup> order Butterworth characteristics by default and are applied to the data streams at the processor level. Notch filters can be applied to the Hi-Res and LFP data streams to remove common noise signals, such as 60-Hz AC line noise (50-Hz in the EU and other countries). The Notch Filters have 2<sup>nd</sup> order Butterworth characteristics. Custom filter settings can be created by contacting [Ripple Support](#).

Front End ID	Front End Type	HiRes Filter	HiRes Notch Filter	LFP Filter	LFP Notch Filter	Spike Filter
NIP[1] FE-A:1	stim front end	0.3-250 Hz	Off	0.3-250 Hz	Off	250-7500 Hz

Figure 3-10 Trellis Instruments – Grapevine processor configuration



- **Front-End User-Controlled Hardware Settings.** The following Front Ends have hardware-level settings that can be user-controlled by selecting a Front End entity in the Instrument Network Panel, as shown in Figure 3-5.
  - **Nano2 and Micro2** – The ADC resolution and high pass filter corner frequency.
  - **Nano2-HV, Nano2+Stim, and Nano2+Stim HC** – The ADC resolution.
  - **Micro2-HV, Micro2+Stim, and Micro2+Stim HC** – The ADC resolution.
- **Stimulation Lookup Tables.** Micro2+Stim and Nano2+Stim FEs and their ‘HC’ variants require stimulation lookup tables to perform accurate stimulation. The stimulation lookup table for a Front End ensures the actual physical stimulation output of that FE matches the nominal output within defined tolerances (see Table 3-1 below).

**Table 3-1** Physical stimulation output tolerances

Stimulation Step-Size ( $\mu\text{A}/\text{step}$ )	Tolerance (Micro2+Stim and Nano2+Stim)	Tolerance (Micro2+Stim HC and Nano2+Stim HC)
1	5% or 5 $\mu\text{A}$	10% or 5 $\mu\text{A}$
2	5% or 5 $\mu\text{A}$	10% or 5 $\mu\text{A}$
5	5% or 10 $\mu\text{A}$	5% or 10 $\mu\text{A}$
10	5% or 10 $\mu\text{A}$	5% or 10 $\mu\text{A}$
20	5% or 20 $\mu\text{A}$	5% or 20 $\mu\text{A}$

In order to use a stimulation Front End, the lookup table for that FE must be loaded onto the Grapevine processor. The database of lookup tables for all stimulation FEs is available for download on the Ripple [website](#). If stimulation FEs are purchased with a Grapevine processor, the processor will come loaded with the appropriate stimulation lookup tables. If the stimulation FEs are purchased after a processor, the latest lookup table database must be downloaded from the website and loaded onto the processor. If the processor does not have the appropriate lookup table for the stimulation Front End, the Grapevine system will not initialize. When this occurs, the port indicator for the FE missing the lookup table will turn red and all other port indicators will turn off. Figure 3-11 illustrates the error message that will appear in Trellis when the up to date stimulation lookup table is not found.

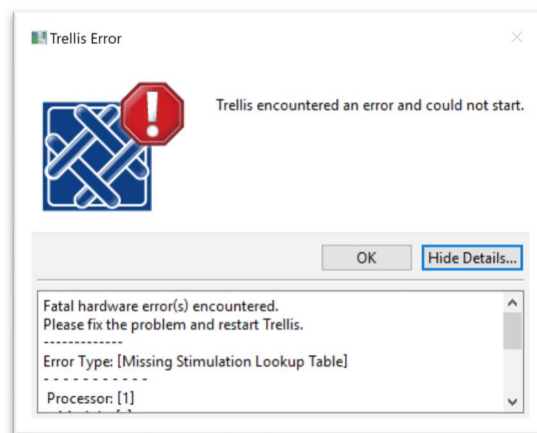

**Figure 3-11** Trellis – Error for missing stimulation lookup table



## Applications

The Trellis software suite contains five applications that provide a range of functionality including real-time visualization of data streams, measurement of electrode impedance, and control of electrode stimulation. These applications are Raster, Spike Grid, Spike Scope, Impedance Analyzer, and Stimulation Controller. Each application can be run by double clicking the icon within the Applications tab of the main Trellis program. The settings for each application can be configured to restore from the last time the application was loaded by going to ‘Tools > Options’. Detailed descriptions of these applications are included in this section.

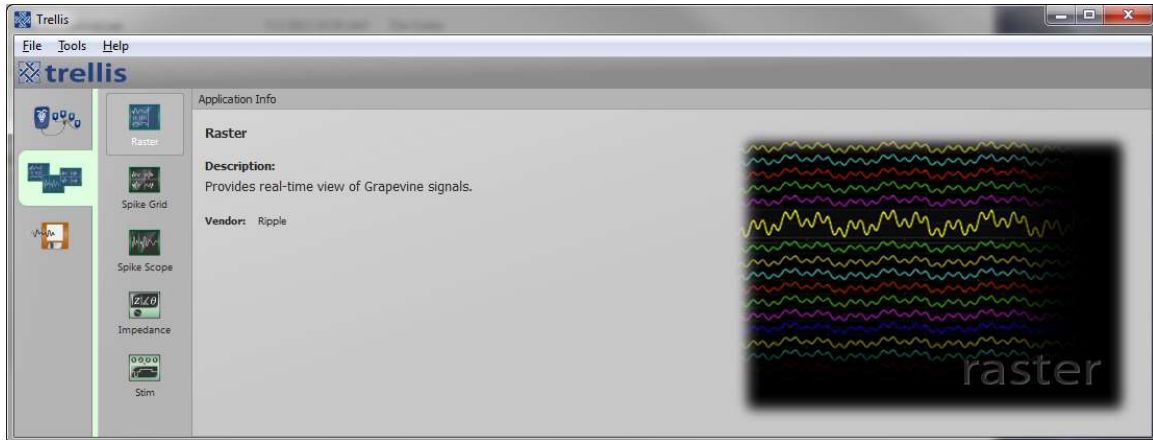

Figure 3-12 Trellis Applications

## Raster

The Raster application provides a raster-based view of all data streams from the Front Ends (FEs). Double clicking on an individual channel launches the Spike Scope application, providing a detailed view of the spike event activity for that channel.

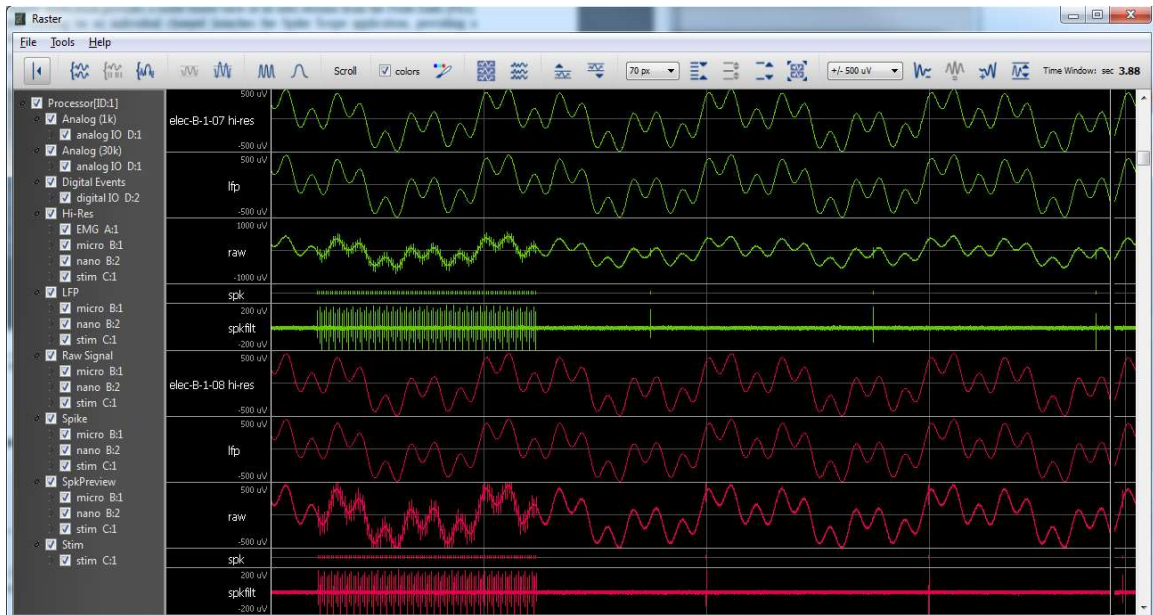























Figure 3-13 Trellis Applications – Raster



The Raster application contains a variety of controls to customize the view. A graphic and description of each control is provided below:

-  Browse available signals and select which ones to display in Raster
-  Group lines by signal type (i.e. spike, Hi-Res, LFP, raw, stim)
-  Group lines by FE input channel
-  Overlay signals from the same FE input channel on one line
-  Turn signal clipping on
-  Turn signal clipping off
-  Increase the time range displayed (decrease sweep speed)
-  Decrease the time range displayed (increase sweep speed)
- Scroll** Toggle between sweeping and scrolling view
- colors** Color waveforms (round robin, by FE input channel)
-  Reset colors
-  Select all lines
-  Unselect all lines
-  Move selected line up
-  Move selected line down
- Set display height for selected lines
-  Decrease display height of selected lines
-  Set display height equal for selected lines
-  Increase display height for selected lines
-  Group selected lines and change display height to fill screen
- Set voltage scale display for selected lines
-  Decrease voltage scale for selected lines
-  Equalize voltage scale for selected lines
-  Increase voltage scale for selected lines
-  Adjust voltage scale to fit signal range for selected lines



## Spike Grid

The Spike Grid application provides a grid view of the spike waveforms for one or more data channels. By default, all FE channels connected through the Grapevine processor are displayed. Double clicking on a channel display launches the Spike Scope application for that channel (see next section for details on the Spike Scope). **Note:** If the width of the Heat Map Display is too narrow, the electrode labels will not be visible.



Figure 3-14 Trellis Applications – Spike Grid

The Spike Grid contains a variety of controls to customize the view. A graphic and description of each control is explained below:

	Opens a dialog box for selecting and loading an electrode map file
	Switch between Spike Grid display shown above and Heat Map display (see following description)
	Set voltage scale on the selected displays
	Decreases the voltage scale on the selected displays
	Increases the voltage scale on the selected displays
	Sets the number of most recent spikes overlaid in display
	Manually clears spikes in selected displays



## Heat Map Display

The Spike Grid application contains a Heat Map display where the frequency of spike events is shown for each Front End channel. The frequency is shown in a color-coded format where the ‘warmer’ end of the color spectrum is used for more frequently active channels. The frequency statistics for all channels are displayed on the right side of the top control bar and can be shown for individual channels by selecting a channel in the grid. By default, all FE channels connected through the Grapevine processor are displayed. Double clicking on a channel display launches the Spike Scope application for that channel (see next section for details on the Spike Scope). **Note:** If the width of the Heat Map Display is too narrow, the electrode labels and some items of the top control bar will not be visible. To view the labels and additional controls, drag the Heat Map Display wider.

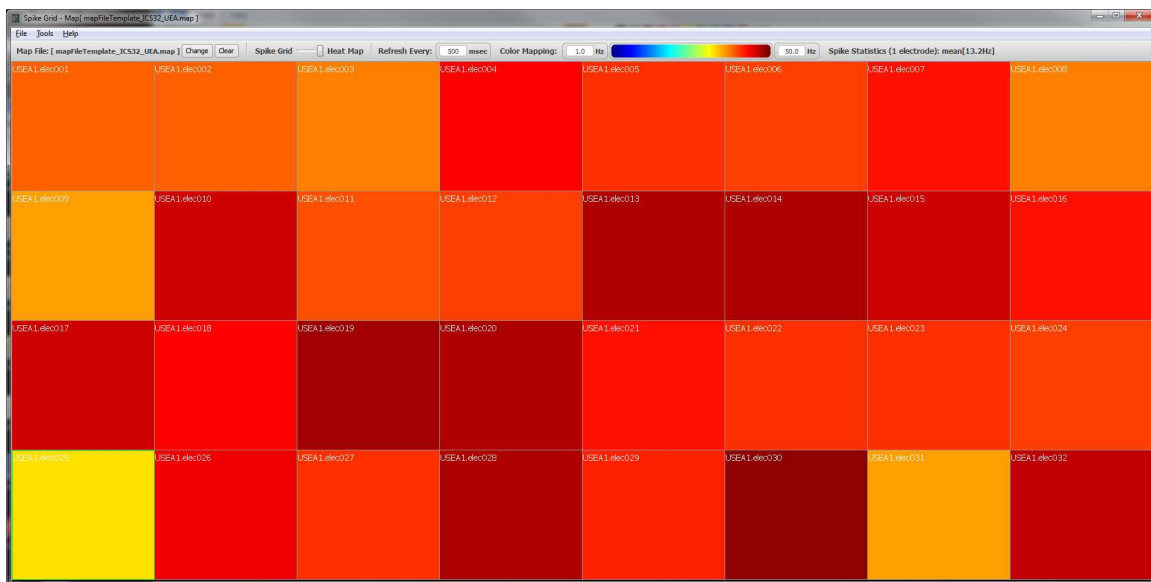

Figure 3-15 Trellis Applications – Spike Grid – Heat Map display

The Heat Map display contains a variety of controls to customize the view. A graphic and description of each control is explained below:

	Opens a dialog box for selecting and loading an electrode map file (see following description)
	Switch between Spike Grid display and Heat Map display
	Set the rate at which the display refreshes
	Set the frequency bounds for the Heat Map display. The values to the left and right of the color wheel are the minimum and maximum frequencies to be displayed.



## Spike Scope

The Spike Scope application provides a detailed view of a channel's spike waveforms and associated spike processing settings such as thresholds and unit definitions. Spike Scope can be launched from the Trellis Applications tab, or from within Raster or Spike Grid by double clicking on a channel display. The Spike Scope displays 52 samples of 30-kS/s data, or 1.7 ms, starting 15 samples prior to threshold crossing. **Note:** Spike events occurring faster than every 1.7 ms will not be completely captured as Spike event data packets do not overlap.

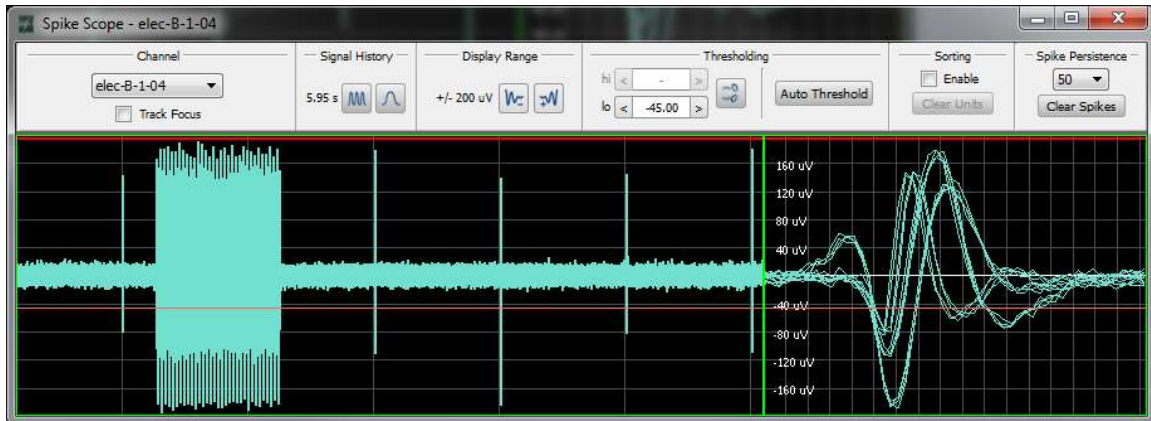
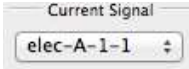
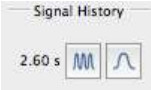



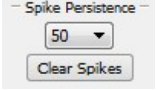
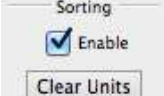

Figure 3-16 Trellis Applications – Spike Scope

The Spike Scope contains a variety of controls to customize the view of this application. A graphic and description of each control is explained below:

-  Specifies the currently displayed channel
- Track Focus When enabled, Spike Scope will track Trellis “focus” (i.e. the last selected channel in Raster or Spike Grid)
-  Increases or decreases the scroll speed in the spike-filtered signal display window
-  Increases or decreases the voltage range of both signal display windows
-  Specifies the current channel's threshold values (see below)
-  Toggles whether the high and low thresholds are mirrored (see below)
-  Specifies the number of most recent spikes overlaid in the spike window. The ‘Clear Spikes’ button clears the display.
-  Enables/disables spike sorting for the current channel. The ‘Clear Units’ button clears current unit definitions for the current channel (see below).





**Configuring Threshold Parameters.** Trellis supports setting both positive and negative thresholds for each channel. Thresholds can be set independently of one another and can be turned on or off at any time. Spike Scope provides three ways to set thresholds. **Note:** Threshold changes made in Spike Scope affect only the currently displayed channel, not the global setting.

1. Dragging the red (positive) or orange (negative) threshold line to the desired value.  
**Note:** Dragging a threshold line to the top or bottom, depending on whether it is a positive or negative threshold, will remove the threshold.
2. Typing the desired threshold in the ‘hi’ or ‘lo’ threshold text fields (Figure 3-16).
3. Selecting the “auto” button will set the threshold using the auto-threshold algorithm. See the Instruments section of this chapter for more details.

If threshold mirroring is enabled, any changes made to a positive or negative threshold via methods 1 and 2 described above, will cause equal and opposite changes to be made to the other threshold.

**Configuring Spike Sorting Parameters.** Trellis possesses the ability to sort spikes online via a time-amplitude method, commonly referred to as the hoop method. Trellis supports the definition of up to four hoops per unit, and up to four units per channel. Spike Scope provides a graphical interface for defining and editing hoop/unit parameters. To turn this interface on, check the ‘Enable’ option in the Sorting control. This will bring up a set of four unit-editing controls in the top right of the spike window (pink, yellow, green, and blue), as seen in the left panel of Figure 3-17 below. To define the first hoop for a given unit, click on the colored circle corresponding to that unit, as shown in the right panel of Figure 3-17 below.

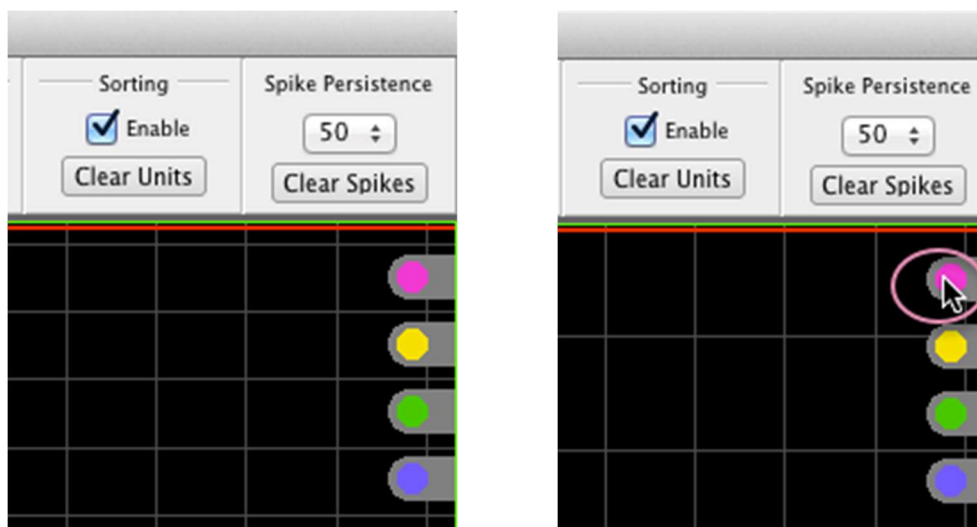
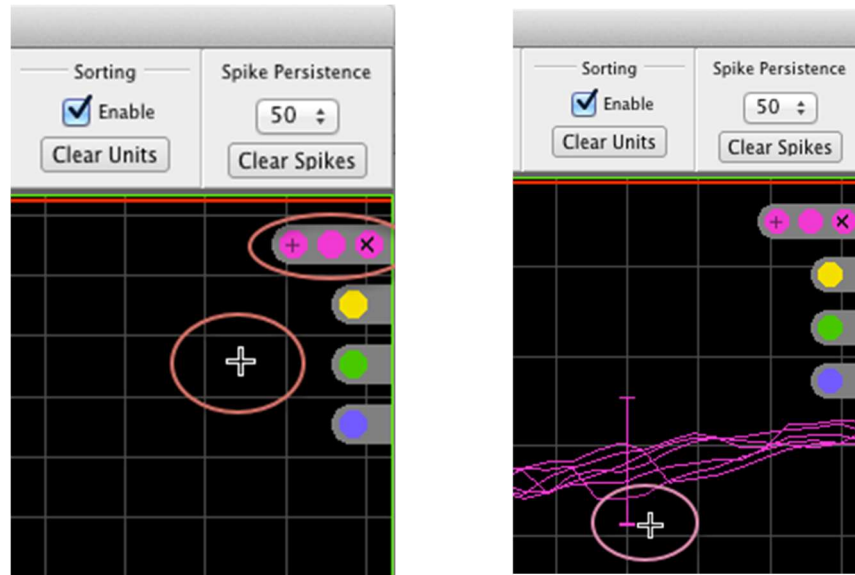

Figure 3-17 Trellis Applications – Spike Scope sorting controls



The unit editing control will expand to reveal three circles and the cursor will change to a + shape indicating hoop drawing mode, as shown in the left panel of Figure 3-18. To define the hoop, click on the display where the hoop should start, and while holding the mouse button down, drag it to the point where the hoop should end. This will cause all spikes that pass through the hoop to change to the chosen color, as shown in the right panel of Figure 3-18. To create another hoop for the same unit, click on the leftmost circle of the control (the one containing a +) and repeat the steps outlined above.



**Figure 3-18** Trellis Applications – Spike Scope sorting – defining a hoop

An existing hoop can be modified in two ways: it can be moved to a new position or it can be expanded in the positive or negative direction. To move the hoop, click on the vertical bar (the cursor will change to a clenched fist), and while holding the mouse button down, drag the hoop to the desired location, as shown in the left panel of Figure 3-19. To change the hoop height, click on an end of the hoop (the cursor will change to a horizontal bar) and drag the end to the desired position, as shown in the right panel of Figure 3-19.

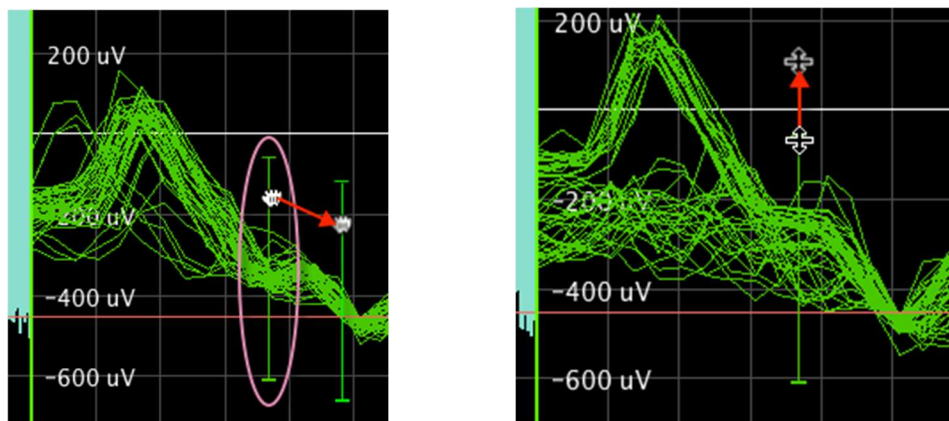

**Figure 3-19** Trellis Applications – Spike Scope sorting – modifying a hoop



Hoops can be deleted in three ways. To delete an individual hoop, drag it to the trash bin at the bottom right of the spike display. The trash icon will turn red when the cursor is in the correct position for the hoop to be deleted, as shown in the left panel of Figure 3-20. To delete all the hoops for a given unit, click on the right-most circle in the unit control bar (the one containing an X). Finally, all hoops on all units can be deleted at once by clicking the ‘Clear Units’ button in the Sorting section of the Spike Scope tool bar, as shown in the right panel of Figure 3-20. The presently defined hoops are not deleted when sorting is disabled. A fully sorted set of three unique spike units is shown in Figure 3-21.

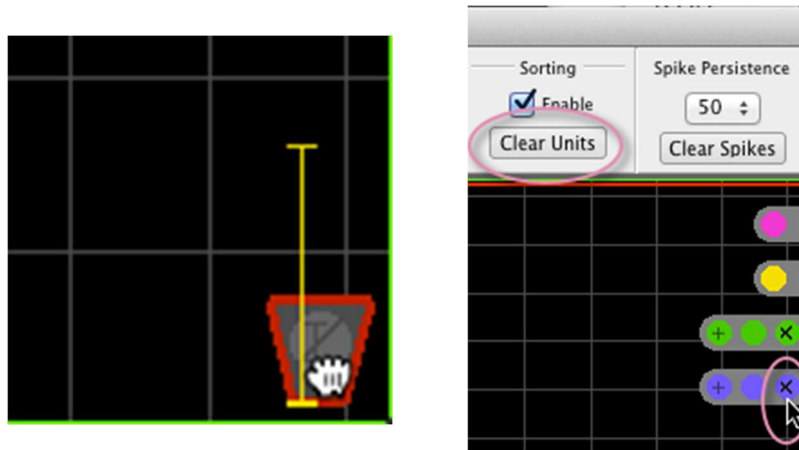

Figure 3-20 Trellis Applications – Spike Scope sorting controls – deleting hoops

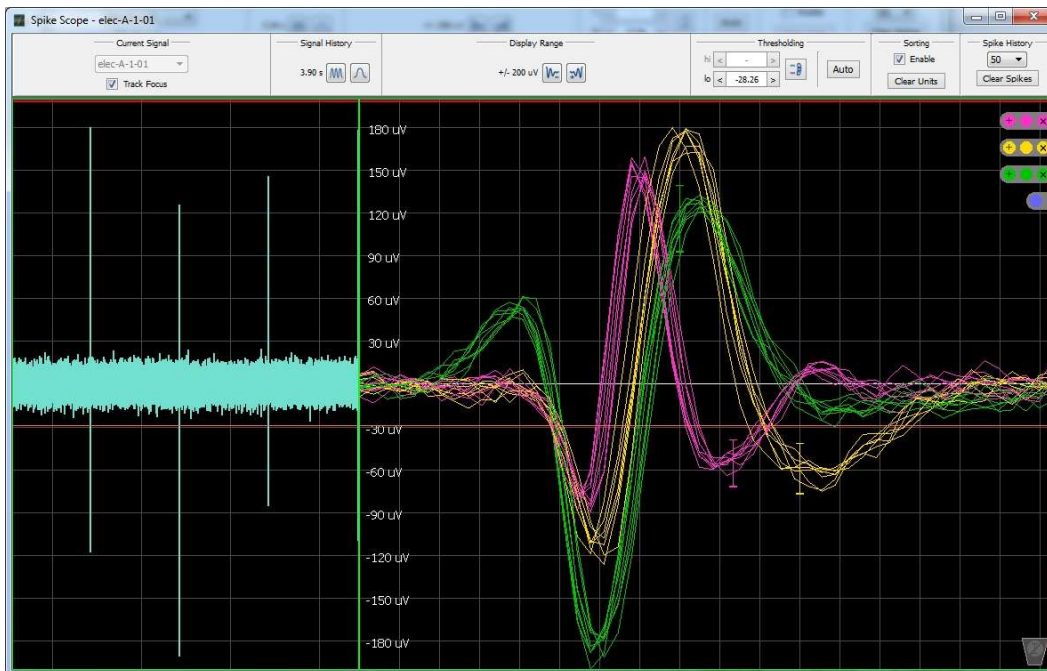

Figure 3-21 Trellis Applications – Spike Scope with sorting enabled for three unique units



## Impedance Analyzer

The Impedance Analyzer can be used to measure the impedance of recording electrodes attached to Front Ends that support impedance measurement. The range of accurate measurement is for electrodes between 10 k $\Omega$  and 1 M $\Omega$  for Nano, Nano2, Micro, and Micro2 and between 10 k $\Omega$  and 400 k $\Omega$  for Nano2+Stim, Nano2-HV, Micro2+Stim, and Micro2-HV. All supported FEs will be displayed on the left hand side of the window when the application is started, and FEs that do not support impedance measurement will be grayed out, as shown in Figure 3-22.

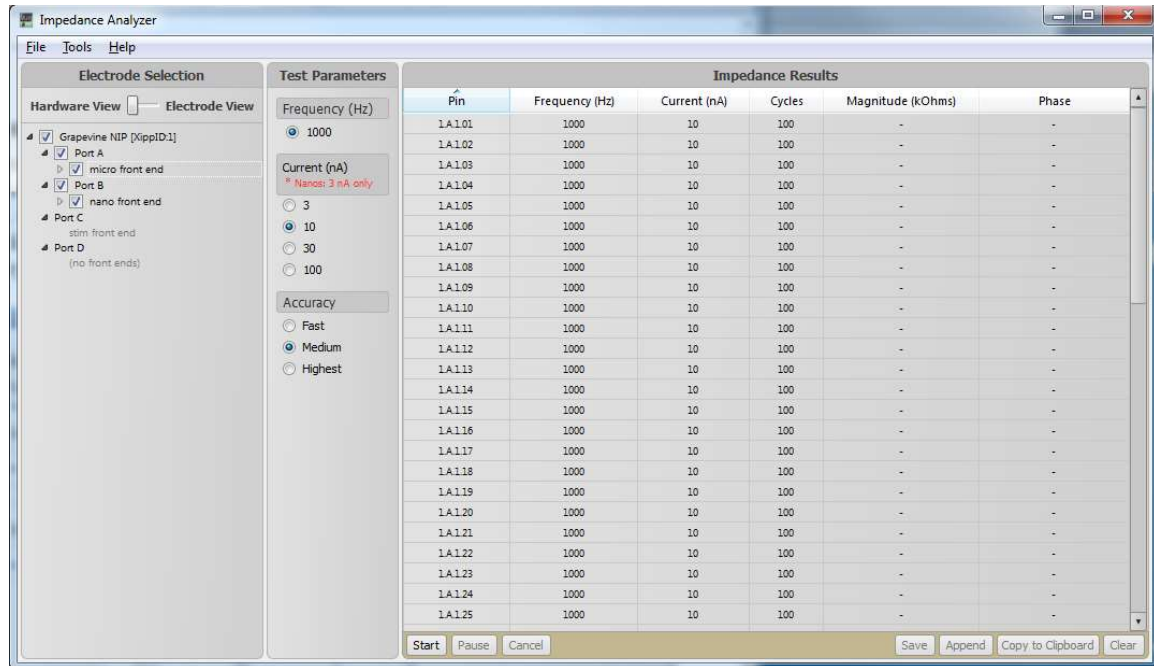

Figure 3-22 Trellis Applications – Impedance Analyzer

Recording electrode impedances are measured using a standard 1-kHz sine-wave at a selectable current level of 3 nA, 10 nA, 30 nA, or 100 nA. The Link 32 Front End can measure impedance using a 100 Hz sine-wave. The accuracy of the impedance measurement can also be selected. The accuracy is a measure of how many trials are averaged to produce each reported value. To run the impedance analyzer, select the desired current level, desired accuracy, and click the ‘Start’ button at the bottom of the Impedance Results panel. When the analysis is complete, the magnitude of each electrode’s impedance, measured in kilohms, along with the phase angle (which indicates the contribution to impedance from resistive versus capacitive effects), will be displayed in the Impedance Results panel, as shown in Figure 3-23. The test parameters can be altered by clicking ‘Clear’ in the bottom right corner to reset the application.

**Note:** Only the 3 nA current level is available for Grapevine Nano and Nano2 Front Ends, and only the 10 nA current level is available for the Nano2-HV, Nano2+Stim, Micro2-HV, and Micro2+Stim Front Ends.

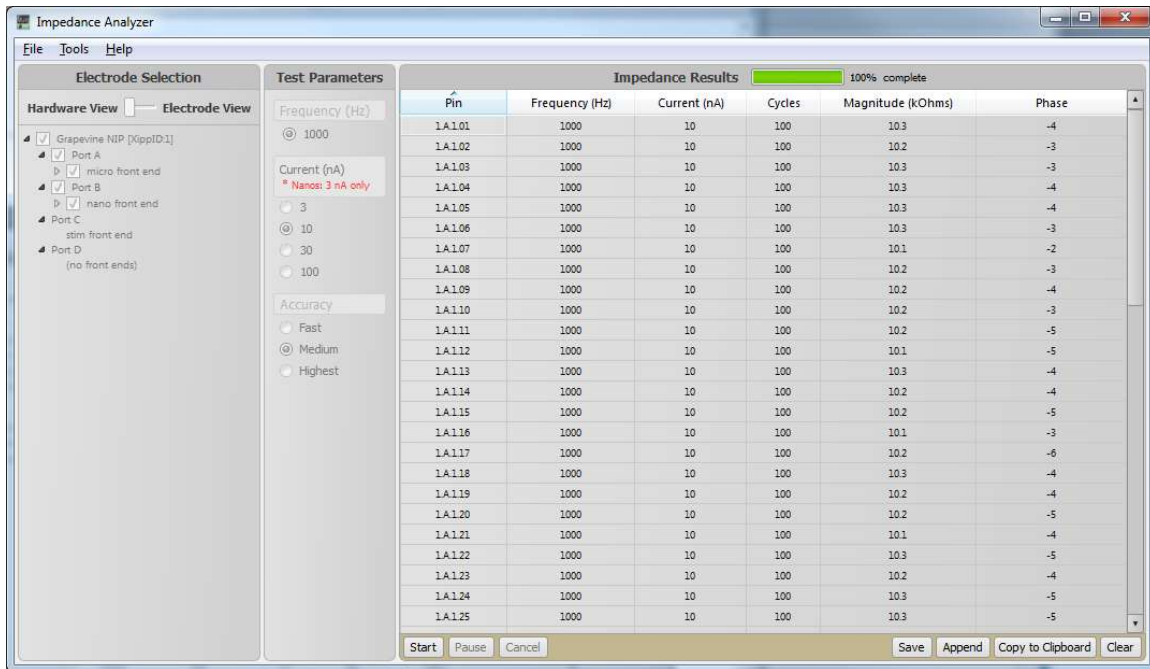

Figure 3-23 Trellis Applications – Impedance Analyzer – completed test with results

The impedance data may be saved in three ways:

1. The results may be saved to a file using a white-space-delimited row format
2. The data may be appended to a previously saved file
3. The data may be copied to the clipboard to be pasted into third-party software

Electrode map files can be used in the Impedance Analyzer. To load a map file, switch the browser panel (on the top left) to ‘Electrode View’ and then click on the browse button. This will allow the impedance results to be sorted in electrode order. The electrode map file must be loaded before starting the impedance run. Impedance test results can be sorted by clicking on any column header in the Impedance Results panel. To make changes to the Electrode Selection panel, the Impedance Results panel must be cleared, using the ‘Clear’ button in the bottom right.

## Stimulation Controller

The Stimulation Controller is used to configure the stimulation parameters for Micro+Stim, Micro2+Stim, Micro2+Stim HC, Nano2+Stim, and Nano2+Stim HC FE channels, referred to as ‘Stim’ Front Ends. Single-pulse, pulse-train, and continuous stimulation patterns can be set for each electrode. Biphasic, phase-balanced, cathodic-leading stimulation is the default pulse shape, but this can be customized using the controls described in this section.

When the application is started, the Stimulation Hardware panel in the top left will display all available Stim FEs and their channels. All other FEs, which do not support stimulation, will be grayed out, as shown in Figure 3-24. The stimulation current step size for Stim FEs is user-controlled and set in the Hardware Description Panel, described later in this section. For the older Micro+Stim FE, the stimulation current step size must be entered when a Micro+Stim is loaded in the Stimulation Controller app for the first time, as shown in Figure 3-25.



After expanding the ‘micro+stim front end’ entity in the Stimulation Hardware panel and selecting an available electrode, a configuration display will appear, as seen in Figure 3-26. This display provides the Front End hardware information and enables the configuration of various stimulation parameters for one or more electrodes as described in the following sections.

**Note:** Stim FEs (excluding Micro+Stim) utilize lookup tables for stimulation output, which is described in the ‘Instrument Configuration’ section of Chapter 3.

**Note:** If Trellis is closed from the main application before stimulation completes or if there are new stimulation parameters set, there may be an additional window open requiring user attention to stop stimulation or save stimulation parameters.

**Note:** There is a known issue with the Stim FEs (excluding Micro+Stim) where simultaneous stimulation on multiple electrodes causes distortion in the stimulation output. Please see the discussion on this topic for these Front Ends in Appendix A.

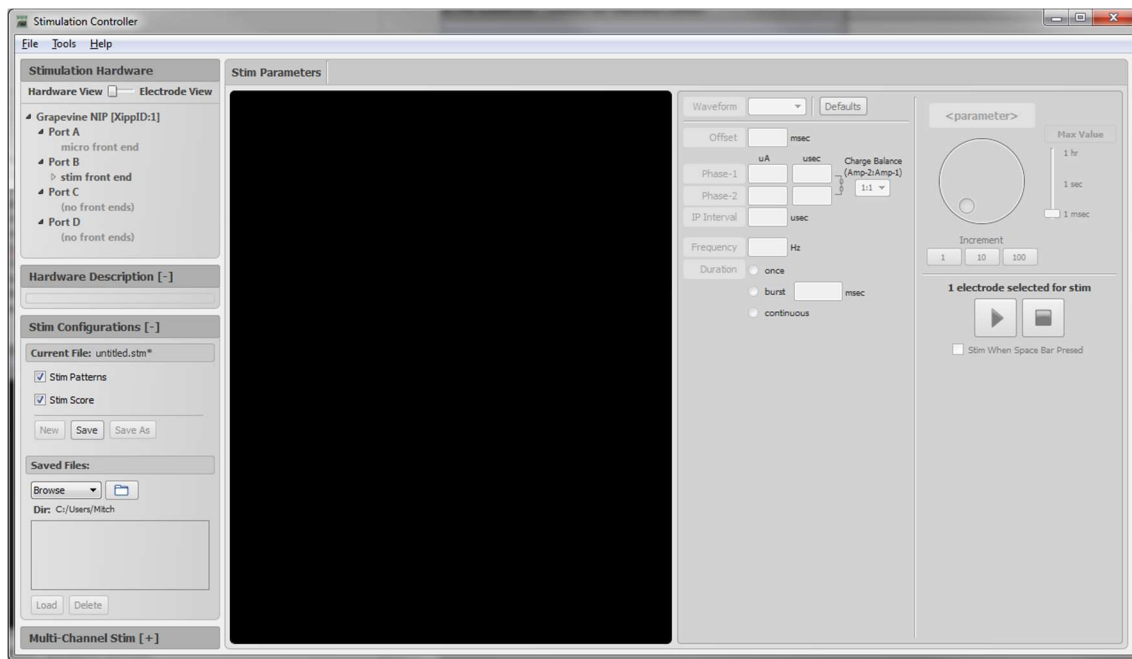

Figure 3-24 Trellis Applications – Stimulation Controller

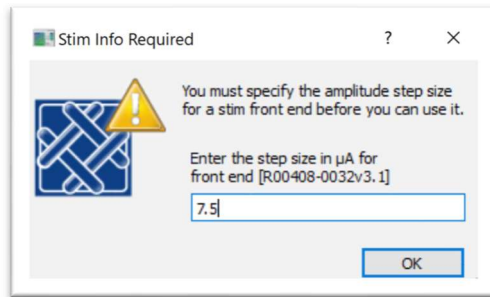

Figure 3-25 Trellis Applications – Stimulation Controller – Stimulation current step size (Micro+Stim)

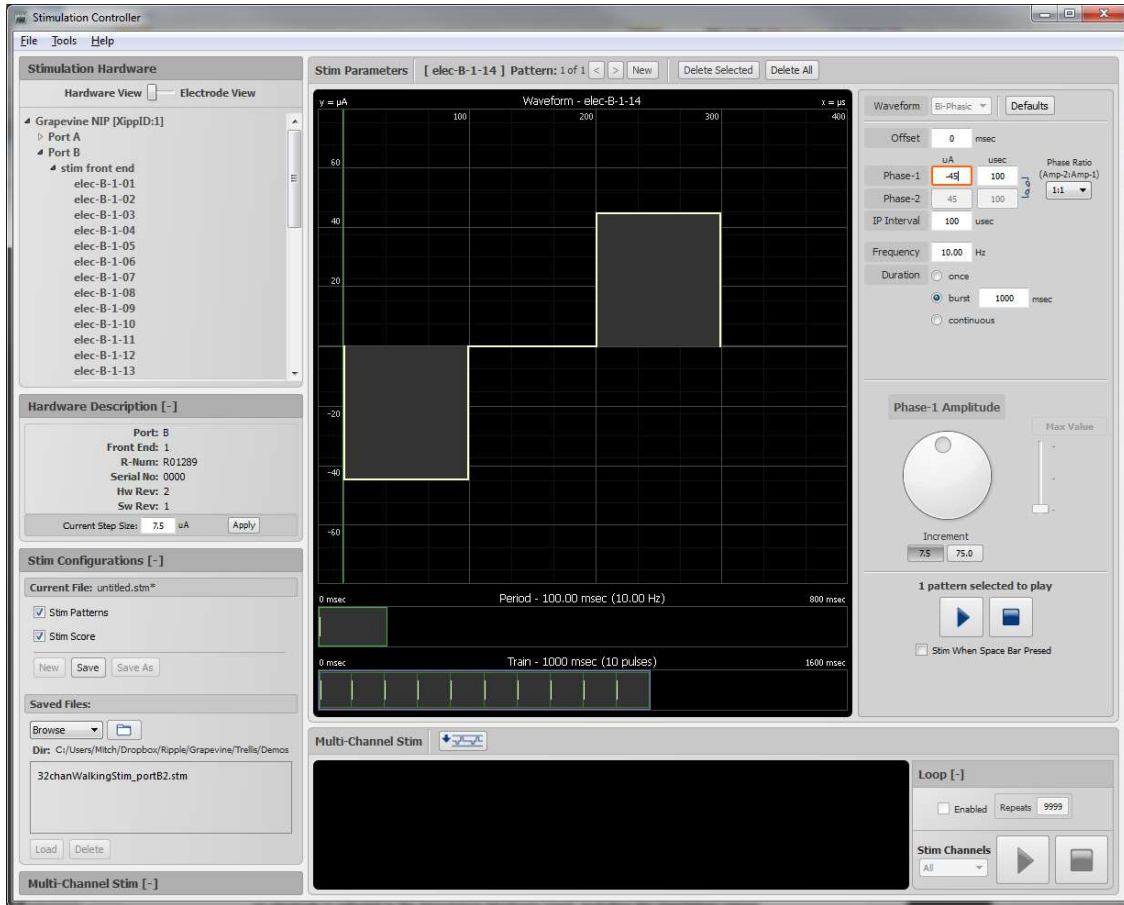

Figure 3-26 Trellis Applications – Stimulation Controller – single electrode stimulation pattern

On the left of the Stimulation Controller window are several information and control panels that can be expanded and minimized by selecting the [+] or [-] next to each panel label. A detailed description of the panels follows (Refer to Figure 3-26):

- **Stimulation Hardware.** This panel displays a list of all available stimulation channels. In parentheses next to each electrode is a label indicating the number of different stimulation patterns that have been created for that electrode. When a channel is selected, its current stimulation pattern is displayed in the Stim Parameters control panel. If no patterns have been defined for a selected channel, a default pattern will be created (indicated by a \* in the channel list, as shown in Figure 3-26). An electrode map file can be used for electrode labeling by switching to ‘Electrode View’ and loading the desired map file.
- **Hardware Description.** The technical specifications of the FE will be displayed here when an electrode is selected in the Stimulation Hardware panel, including the stimulation current step size, shown as 7.5  $\mu\text{A}$  for the Micro+Stim FE in Figure 3-26. For Micro+Stim FEs, this is the discrete amplitude step size that is programmed in the FE at the time of production. The step size value must be entered when the Micro+Stim is first loaded in the Stimulation Controller app (Figure 3-25). If the wrong value is entered, the step size can be changed by altering the value and selecting ‘Apply’. For all other Stim FEs, this amplitude step size is user-selected through a drop-down menu.



- **Stim Configuration.** This panel enables the saving of individual electrode stimulation patterns that have been defined, as well as the multi-channel stimulation score (described below). This may be useful when using a large number of electrodes and/or defining complex stimulation patterns. A saved configuration file (\*.stm) can be loaded or deleted from this panel.
- **Multi-Channel Stim.** The control for expanding and collapsing the Multi-Channel Stim display is contained on the left side of the Stimulation Controller window. By default, this panel is collapsed and can be expanded by clicking the [+] symbol.

On the right of the Stimulation Controller window are the Stim Parameters and Multi-Channel Stim control panels. Below is a detailed description of each panel.

**Stim Parameters.** This panel enables the display of and control over the parameters of the present stimulation pattern for one or more channels/electrodes. The parameters for any channel's present stimulation pattern can be viewed by clicking on that channel in the hardware list. If multiple electrodes are selected, the present pattern for each channel is displayed in the "Preview" section of the Stim Parameters panel. The present pattern for multiple electrodes can be adjusted by selecting them from the "Preview" section. When multiple previews are selected, controls corresponding to parameters that are not the same across the selected patterns will be blank. In the simplest use case, each channel will have only one pattern; however, it is possible to define multiple patterns for each channel. To create a new pattern for the present channel (or if multiple channels are selected in the preview column) click the 'New' button in the panel toolbar. To change the present pattern for a channel, select only that channel and then use the [<] [>] buttons in the panel title bar to navigate through the set of defined patterns. The time and amplitude scales of the different stimulation pattern displays can be increased or decreased by positioning the cursor over the display and using the mouse wheel + Shift or mouse wheel + Alt, respectively.

A stimulation parameter can be changed either by entering a numerical value in the corresponding field or by selecting the field (noted by an orange box around it), and then using the parameter dial pictured below the parameter fields in Figure 3-26 and close-up in Figure 3-27 below. The dial can be rotated by clicking on it and dragging the mouse, or by positioning the cursor over the dial and rotating the mouse wheel (hold down Shift for a larger step size). The increment for changes in parameter value can be set by selecting one of the values below the dial and the maximum allowable parameter value can be set by moving the slider bar to the right of the dial.

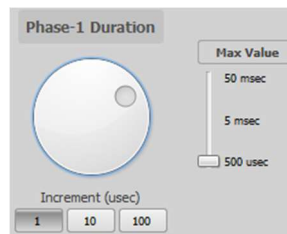

**Figure 3-27** Trellis Applications – Stimulation Controller - Parameter dial

Descriptions of the various stimulation pattern parameters and their defaults are as follows:

- **Offset.** This control specifies the time (in milliseconds) from the beginning of the stimulation period to when the leading phase of the stimulation pattern begins. The default for this parameter is 0 ms, and in most cases it will not need to be changed. Interleaved stimulation across multiple electrodes is an example of a stimulation paradigm where the offset parameter is used. For a given stimulation period, the maximum offset is the period minus the length of the stimulation waveform.





- **Phase-1.** These two controls specify the parameters of the leading phase of the stimulation waveform. The default amplitude is three times the stimulation step size (specific to the FE) and the default duration is 100  $\mu$ s. The maximum amplitude is  $\pm 100$  current steps (750  $\mu$ A for the 7.5  $\mu$ A step-sized stim FE shown) and the maximum duration is 50 ms. The duration resolution is 1  $\mu$ s.
- **Phase Ratio.** This control specifies how the amplitude ratio and the duration ratio between the two phases of stimulation are implemented. The choices are Open, 1:1, 1:2, 1:4, and 1:8. A phase ratio of 1:2 means that the second phase will have half the amplitude of the leading phase, but the duration will be twice as long. Selecting the ‘Open’ phase ratio allows the user to have direct control over the Phase-2 parameters (described below). The default charge balancing is 1:1. Because some Stim FEs have a large stimulation amplitude step size, it is not always mathematically possible to achieve the specified ratio between phase parameters. When this is the case, the closest valid phase settings are used. **Note:** The Stim FEs are capacitively-coupled, which ensures total charge balance over time for all stimulation pulses.
- **Phase-2.** These two controls specify the parameters of the second phase of the stimulation waveform. If Phase Ratio is set to anything besides ‘Open’, these two controls will be disabled and automatically updated to reflect the desired phase ratio. As with Phase-1 parameters, the default amplitude is three times the stimulation step size (specific to the FE) and the default duration is 100  $\mu$ s. The limits and resolution are the same as for Phase-1.
- **IP Interval.** This control specifies the interphase interval (in microseconds) between Phase-1 and Phase-2 of the stimulation waveform. The maximum duration is 50 ms. There is technically no minimum duration for the IP Interval; however, due to constraints of the stimulation hardware, the minimum allowable IP Interval is determined such that the IP Interval + Phase-1 duration is a multiple of the 30-kHz state machine clock cycle (33.3  $\mu$ s). E.g., if the Phase-1 duration is set to 210  $\mu$ s, the minimum allowable IP Interval is 23  $\mu$ s. An IP Interval of zero is possible if the Phase-1 duration itself is a multiple of the clock cycle (e.g., if the Phase-1 duration is 100  $\mu$ s).
- **Frequency.** This field specifies the frequency (in Hertz) of the pulse train when more than one pulse is desired. The maximum allowable frequency is 1 kHz. If the offset is non-zero, a maximum bound will be set for the frequency. Specifically, the frequency cannot be higher than that at which the period equals the sum of the offset and pulse duration. If using a burst of stimulation (see Duration parameter on the following page), and the duration of the stimulation train is not an integer multiple of the stimulation period (1/frequency), a warning will be displayed next to the Frequency parameter as shown in Figure 3-28, and the train will have an empty partial period at the end of the pattern, noted by a red box in the Train Display. The warning text can be refreshed by clicking on the warning symbol .
- **Duration.** This sets the total time of stimulation (in milliseconds) for the current stimulation pattern. The choices are:
  - once – only a single pulse will be delivered.
  - burst – multiple pulses will be delivered at a selected frequency for a set amount of time. The maximum allowable time for a pattern is 1 hr. If the duration of the stimulation train is not an integer multiple of the stimulation period (1/frequency), a warning will be displayed next to the Frequency parameter as shown in Figure 3-28 below, and the train



- will have an empty partial period at the end of the pattern, noted by a red box in the Train Display. The warning text can be refreshed by clicking on the warning symbol 
- continuous – stimulation will occur continuously at a selected frequency until the stop button is pressed.

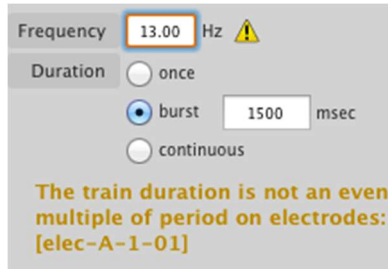

**Figure 3-28** Trellis Applications – Stimulation Controller – Burst Duration Warning

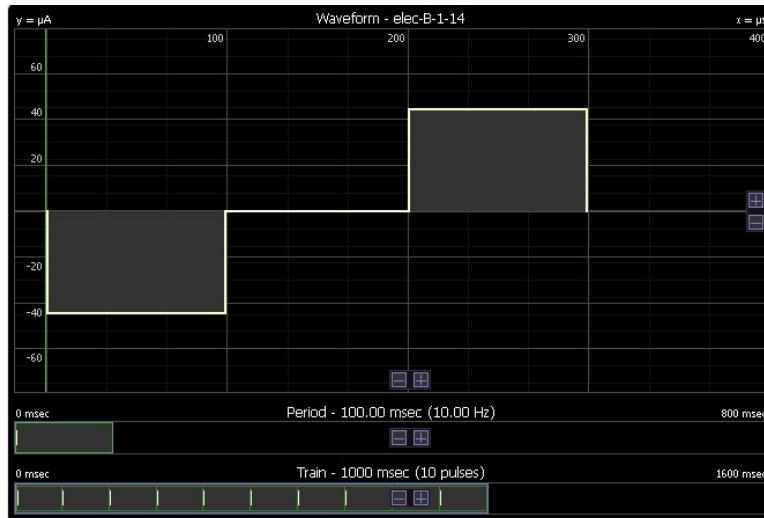



**Figure 3-29** Trellis Applications – Stimulation Controller – Waveform, Period, and Train Display

**Waveform Display.** Shown in the top center of Figure 3-26 and in Figure 3-29, the Waveform display shows one cycle of the stimulation parameters for Phase-1, the IP Interval, and Phase-2. The time and amplitude scales of the Waveform display can be altered by positioning the cursor over the Waveform display and using the [+][-] buttons that appear, or by holding down the Shift key (Alt for amplitude), and then scrolling the mouse wheel.

**Period Display.** Shown below the Waveform display in Figure 3-29, the Period display shows a single period of stimulation for the present stimulation pattern. The Offset time and the entire duration of stimulation are depicted. The time scale can be changed by positioning the cursor over the display and using the [+][-] buttons that appear, or by scrolling the mouse wheel while holding down the Shift button.

**Train Display.** Shown below the Period display in Figure 3-29, the Train display shows all stimulation pulses for the present stimulation pattern. The onset of each stimulation pulse is noted by a tick mark in the Train display. The time scale can be changed by positioning the cursor over the display and using the [+][-] buttons that appear, or by scrolling the mouse wheel while holding down the Shift button.



**Multi-Channel Stim:** This panel provides a means for constructing stimulation “scores” involving one or more electrodes and one or more patterns per electrode, as shown in Figure 3-30 below. By default, this panel is collapsed and can be expanded by clicking the [+] symbol next to Multi-Channel Stim on the bottom left of the Stim Controller app. A stimulation pattern for an electrode can be added to the Score by selecting the pattern in the “Preview” section of the Stim Parameters panel and then clicking on the  button on the top of the Multi-Channel Stim panel. The pattern will be added to the Stim Score at the end of the present set of patterns for the channel. You can edit any pattern in the Stim Score by selecting it (indicated by an orange box surrounding the pattern in the Score). **Note:** When patterns are added to the score, a pointer to the original pattern is created; i.e., patterns are not replicated when added to the score. Thus, if a pattern is edited in the Stim Parameters panel that is used in the score, it will change the pattern in the stimulation score. An individual stimulation pattern can be removed from the stimulation score by selecting it and clicking on the  button in the panel tool bar. Channels (and all of their patterns) can be removed from the stim score by clicking on the channel label and then clicking the  button. A single pattern for multiple electrodes can be selected by clicking on a pattern and then dragging the mouse pointer up or down. The time scale (x-axis) of the stim score can be altered by positioning the cursor over the display and using the [+] [-] buttons that appear, or by scrolling the mouse wheel while holding down the Shift button.

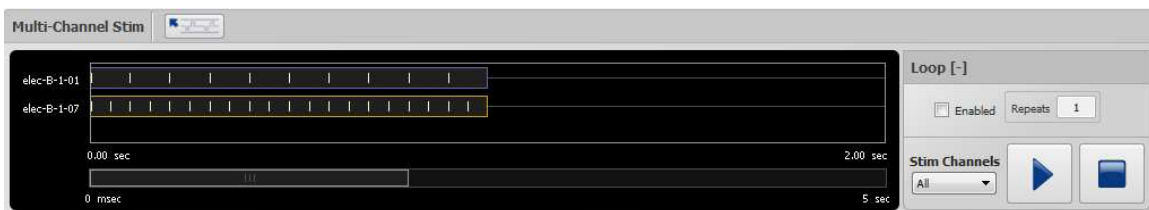

**Figure 3-30** Trellis Applications – Stimulation Controller – Multi-Channel Stim Display

**Note:** Any warnings or errors will be displayed on the top bar of the Multi-Channel Stim Panel, as shown in Figure 3-31. If the duration of stimulation for a pattern is not an integer multiple of the stimulation period (1/frequency), the train will have an empty partial period at the end of the pattern, noted by a red box in the Stim Score, as shown in Figure 3-31. Patterns that are less than 10 ms in duration cannot be executed in line with other patterns in the multi-channel stim score. Patterns that are less than 25 ms in duration are not recommended for more than 128 channels of stimulation.

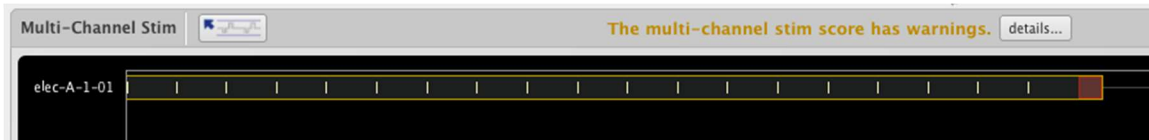

**Figure 3-31** Trellis Applications – Stimulation Controller – Multi-Channel Stim Display Warnings & Errors

Once the stimulation parameters have been set for one or more electrodes, the stimulation can be executed by clicking on the play button to the right of the Stim Parameters panel display or the play button to the right of the Multi-Channel Stim display. **Note:** When executing stimulation scores, a Stimulation Safety Switch similar to Figure 3-33 will appear in the top right of your computer display. This can be used to safely stop all stimulation if an adverse event occurs. This runs as a separate application to the Stimulation Controller app so that stimulation can be stopped immediately if necessary.



The Stim Parameters panel play button, shown in the top of Figure 3-32 below, will execute the current pattern on the channels selected in the “Preview” column. Pressing the space bar for stimulation execution can be enabled for quick repetition and/or easier control of stimulation (the control is located under the play and stop buttons). **Note:** Because the Stimulation Safety Switch is its own application, it does not close when the Stimulation Controller application is closed, or when Trellis is closed.

- The play button to the right of the Multi-Channel Stim display, shown in the bottom of Figure 3-32 below, is used to execute the multiple electrode stimulation score. By selecting one of the two options in the “Stim Channels” dropdown menu, the play button can be used to execute either the entire stim score (“All”) or just the patterns for the selected set of electrodes (“Selected”), by clicking the electrode labels to the left of the stim patterns. The Multi-Channel Stim panel includes an option for executing the stimulation score on loop. In this mode, the Multi-Channel Stim player repeats the entire stimulation score (or patterns on the selected set of channels) for the specified iterations.



Figure 3-32 Trellis Applications – Stimulation Controller - Stimulation execution controls



Figure 3-33 Trellis Applications – Stimulation Controller – Safety switch



## File Save

File Save provides an interface to specify which data streams will be recorded, as well as to start, pause, and stop individual recordings. For each recording, the file name and comments can be specified. The performance of the data acquisition system is strongly dependent on the speed of the file media being used; data should only be recorded to a local hard drive. If data files are to be stored on a network drive, it is recommended that the data files be moved after recording is finished.

**Note:** The NEV Specifications document details how the data is stored in the saved Trellis files. The document is provided with the Trellis software suite and is also available on the Ripple [downloads](#) webpage. Data is stored according to channel IDs which are numbered 1-5120 for Front End recording channels, 5121-10240 for Front End stimulation channels, and 10241-10270 for analog input channels (4 SMA, 24 grouped, and 2 audio inputs). Digital input events are stored in the \*.nev file under packet ID 0. Recording channels of Front Ends connected to port A of the first Grapevine processor are numbered 1-128, then 129-256 for port B, etc. Recording FE channel IDs are numbered 1-5120 to allow for recording from multiple NIPs by one computer running Trellis, which may be enabled in a future software release. A sample saved data set that includes spikes, LFP, Hi-Res, raw, stim, digital input, and analog input data may be downloaded from [here](#).

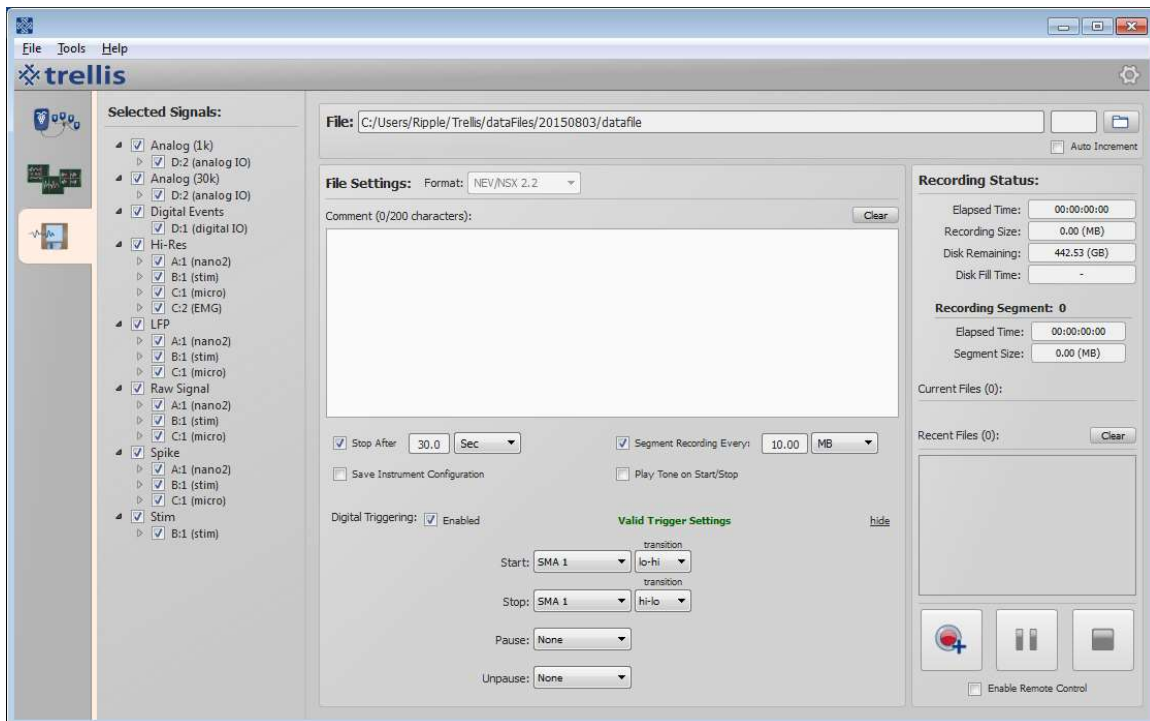

Figure 3-34 Trellis File Save

- **Selected Signals.** This panel enables the selection of individual channels and data streams to be recorded.



- **Raw Signal** includes a continuous waveform data stream containing the entire bandwidth of the FE amplifier. The raw data is sampled at 30 kS/s per channel. This data is saved in the .ns5 file format.
- **EMG** streams can be enabled for Link Front Ends and contain continuous waveform data sampled at 2 kS/s. The EMG signals are digitally filtered using a low pass IIR filter of 500 Hz (default) with 4<sup>th</sup> order Butterworth characteristics. This data is saved in the .ns3 file format.
- **Hi-Res** contains a continuous waveform data stream with 24-bit floating point precision which allows for better precision at the low end of the spectrum as well as a greater dynamic range, which can be useful for ECoG and EMG data. The Hi-Res signals are sampled at 2 kS/s and are digitally filtered using a low pass IIR filter of 500 Hz (default) with 4<sup>th</sup> order Butterworth characteristics. This data is saved in the .nf3 file format.
- **HiFreq** streams can be enabled for EMG Front Ends and contain continuous waveform data with 24-bit floating point precision allowing for better precision at the low end of the spectrum and wider dynamic range. The HiFreq signals are sampled at 7.5 kS/s and are digitally filtered using a low pass IIR filter of 2000 Hz (default) with 4<sup>th</sup> order Butterworth characteristics. This data is saved in the .nf6 file format.
- **HW Status** streams can be enabled for Link Front Ends and contain continuous implant and transceiver information. This data is sampled at 2 kS/s and is saved in the .ns3 file format.
- **LFP** includes a continuous waveform data stream for low frequency waveforms such as LFP, ECoG, EEG, and EMG. The LFP data stream is sampled at 1 kS/s per channel and digitally filtered using a low pass IIR filter of 250 Hz (default) with 4<sup>th</sup> order Butterworth characteristics. This data is saved in the .ns2 file format.
- **Spike** data includes timestamped neural events that cross the user-defined threshold. The spike data is sampled at 30 kS/s per channel and is digitally filtered with a high pass filter of 250 Hz (default). The Spike data is stored in a 1.7 ms (52 sample) data segment in the .nev file format. **Note:** The Timestamp associated with each spike event is the beginning of the 52 sample spike window (15 samples prior to threshold crossing), not the spike threshold crossing event itself. **Note:** Spike events occurring faster than every 1.7 ms will not be completely captured as Spike event data packets do not overlap.
- 1 kS/s [**Analog (1k)**] and 30 kS/s [**Analog (30k)**] data streams can be selected for the Analog I/O Front End. The Analog I/O data is not filtered. These data streams are saved in the .ns2 and .ns5 file formats, respectively.
- 10 kS/s data streams can be enabled for the Digital I/O Front End (**Digital Events**). This data is saved in the .nev file format.
- **Stim** data contains the voltage waveforms supplied by the Stim FE during stimulation. The Stim data is acquired in continuous 1.7 ms segments for each stimulation pulse, from the time when the stimulation pulse starts until the end of the monophasic or biphasic stimulation waveform (including the interphase interval). A single stimulation pulse may span multiple data segments if long pulsewidths are used, and a single data segment may contain multiple stimulation pulses if very high frequency stimulation is used. The Timestamp stored for each data segment is associated with the first sample acquired in the data segment. The Stim data is saved at 30 kS/s (52 samples) in the .nev file format.

**Note:** The Hi-Res and HiFreq data streams are the only options available for the EMG FE.



- **File Name.** The default file name is ‘datafile’. The file name for the recording can be specified by typing a name in the File text field. The directory for saving files can be selected by clicking on the folder button to the right of the File text field. File extensions are automatically set depending on the type of data recorded.
- **Auto Increment.** When this box is checked, filenames will include numbers at the end of their names (e.g. c:\datafile0002.nev). The number will be automatically incremented as data files are collected and the number of initial leading zeros will be preserved. The starting number can be changed by entering a new value in the numerical field.
- **Comments.** This field contains a comment (up to 200 characters) that is inserted in the header region of the data files. Multiple lines can be entered with Ctrl+Enter. However, only eight lines of text will be saved.
- **Stop After** (timed recording). With the “Stop After” box checked, specify an amount of time (in seconds, minutes, hours, etc.) for the Grapevine to record data. Once the time has expired, the recording will stop automatically.
- **Segment Recording Every.** When this box is checked, files will be saved with the maximum data size or time length selected. When the specified data size or time length is reached for the current data file, additional data will be saved to a new data file. Segmented data files will use an auto-segment suffix date or number, which can be set from the Trellis Settings window, as shown in Figure 3-2.
- **Play tone on Start or Stop.** When this box is checked, a tone will play from the computer when recording is started and stopped.
- **Save Instrument Configuration.** When this option is enabled, an instrument configuration file (\*.xfg) will be automatically created with each data file. This file can be loaded at a later time within the Instruments configuration interface to recall the settings of the hardware, data streams, threshold settings, and any hoops placed during online spike sorting.
- **Digital Triggering.** This panel enables the configuration of Trellis to start, stop, pause, and resume file recording when it receives LVTTL inputs from an external source through the Digital I/O FE. If triggering is being used, valid non-overlapping LVTTL input values must be specified for the start and stop triggering functions. Specifying pause and resume triggering functions is optional and can only be used in conjunction with start and stop. LVTTL values can be specified for an individual Digital I/O SMA port or a 16-bit hexadecimal pattern on the parallel port. If a 16-bit hexadecimal pattern is used for triggering, the pattern value must be between 0x0000 and the mask level selected.
- **Recording Status.** During data acquisition, the right panel displays the status of the current recording, including elapsed time of the recording, file size, available storage remaining, and recently recorded data files.
- **Start Recording Button.**  Press this button to begin recording.



- **Pause Recording Button.** Press this button to pause recording. Press it again to resume recording.
- **Stop Recording Button.**  Press this button to stop file recording and save the data file.
- **Enable Remote Control.** When this option is enabled, other PCs connected to the instrument network can (via UDP) instruct File Save to start, pause, and stop recording. Contact Ripple technical support for more information about controlling Trellis via UDP.

**Note:** If a port error occurs while saving data, an error message will appear in Trellis and an audible warning tone will play until ‘ok’ is pressed as seen in Figure 3-35.

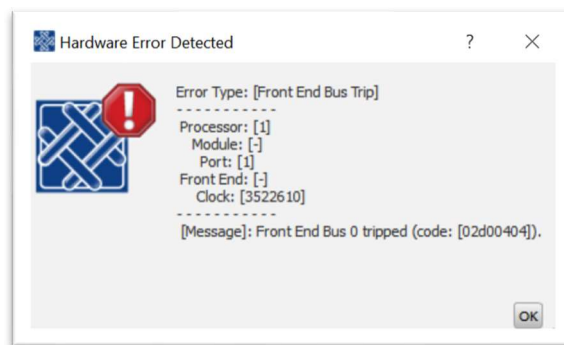

**Figure 3-35** Trellis File Save – Port Error

## Two Processor Synchronization

It is possible to expand a single Grapevine system by time-synchronizing two Grapevine systems together, using a special Processor Sync Cable provided by Ripple, and by connecting the Trellis computers on a separate physical Ethernet subnet. In a synchronized two-processor system, the Front End data acquisition by the two processors will utilize the same sampling clock, ensuring exact time alignment for continuous, digital, and spike-event data. Time-synchronized Grapevine processors operate in a master/slave relationship, where the master processor generates the clock signal for the slave. The Trellis instances operate as peers, where the File Save interface on either computer can be used to start, stop, and pause recording.

To set up two-processor synchronization, each Grapevine processor must be connected to a separate computer running Trellis. The processors must be connected together, via their auxiliary (“aux”) ports with a special proprietary RJ45(Ethernet)-like cable built by Ripple, a Processor Sync Cable (PN: R02501). A colored band on one end of the Processor Sync Cable denotes which processor will function as master. The computers running Trellis must be connected to each other on a second Ethernet subnet separate from the network connecting each computer to its Grapevine processor.

At power-on, a processor automatically determines its operating role (i.e. master, slave, or stand-alone) within the first ten seconds. The processor will default to stand-alone mode if a Processor Sync Cable is not present or one end is unplugged.

**Note:** Two processor synchronization is not a feature of the Trek.





## Hardware & Software Setup

- Follow the instructions in Chapter 2 to configure the network card that will connect a processor to each host computer.
- Ensure both computers are running Trellis 1.7.0 or higher.
- Insert the color-banded “master” end of a Processor Sync Cable into the auxiliary port of the one of the processors and insert the other end of the cable into the auxiliary port of the other processor (it does not matter which serves as slave and which serves as master).
- Connect the two Trellis computers with an Ethernet cable. The network adapter on each computer used for this connection must be configured similarly to the network connection to the processor, using a different subnet and IP address. For example, one of two Trellis computers can be configured with IP address of 192.168.43.1 and the other can be configured with an IP address of 192.168.43.2. All other settings such as subnet mask and firewall settings should be configured according to the stand-alone mode instructions of Chapter 2.

## Initializing & Enabling Synchronization

- After establishing all of the appropriate network connections, the two-processor synchronized system is now ready for initialization. First, make sure both processors are in standby mode, denoted by a blue power status light. Then, press the power button for both processors and wait for each processor to complete its initialization process, indicated by a green light on all the ports to which Front Ends are connected. Both processors must be initialized within ten seconds of each other for synchronization to occur.
- Start Trellis on each of the host computers (synchronized Trellis startup is not required). Icons indicating the state of processor and Trellis synchronization are displayed in the upper-right corner of the Trellis program. The different possible states and icons are detailed below.



Both processor sync and Trellis sync is good



Processor sync is good, Trellis instances are not synchronized



Neither the processors nor the Trellis instances are synchronized

- The two instances of Trellis must be configured to look for one another on the Trellis-Trellis network. This is accomplished via the Recording Synchronization Form located at the bottom right corner of the File Save interface, as shown in Figure 3-36 below. If you do not see this form you can enable it by checking the “Show Trellis Recording Synchronization Form” option, found in the ‘Tools>Options’ menu. This option is enabled by default and will remain enabled when you restart Trellis. If you do not see the Recording Synchronization Form or the “Show Trellis Recording Synchronization Form” menu option, it means that the processors are not synchronized. Check that both ends of the Processor sync cable are seated properly and restart the processors.
- Once the two instances of Trellis are running and the Recording Synchronization Forms are visible, enter the Trellis-Trellis Subnet configured earlier in each Trellis instance.



- On each computer running Trellis, enable the “Enable Recording Sync” checkbox at the bottom of the Recording Synchronization form. The Recording Synchronization Form will change color to green if Trellis-Trellis synchronization is established. If either of the Trellis instances experiences an error locating the other Trellis instance, the Recording Synchronization Form will change color to yellow and a message will appear, similar to Figure 3-37. Note, the first Trellis instance that is enabled to sync will show a warning until “Enable Recording Sync” is enabled on the other instance. If the error remains after recording sync has been enabled on both computers, there is a Trellis-Trellis synchronization problem. Re-examine firewall and adapter settings relevant to the Trellis-Trellis network.

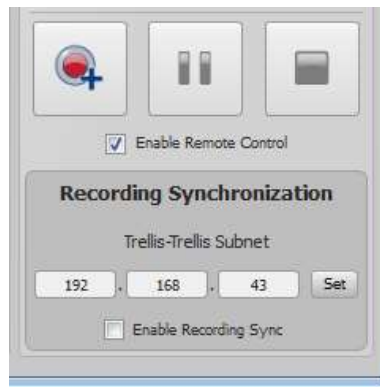

Figure 3-36 Trellis File Save - Recording Synchronization Form



Figure 3-37 Trellis File Save – Recording Synchronization error

If all goes well and both processor and Trellis synchronizations initialize correctly, time-synchronized data recordings can be acquired by starting a file save session from either Trellis instance.



There are two ways in which synchronized data recordings can be disrupted. Both will trigger warning or error dialogs in the Recording Synchronization Form.

- If the Trellis-Trellis network is interrupted, the Recording Synchronization Form will change color to yellow, as shown in Figure 3-37. If this occurs during a recording, a dialog box will appear giving the user the option to stop or continue recording. **Data recording will continue unless the user chooses the stop recording option.** In this circumstance the data being recorded by each Trellis instance are still synchronized. You can continue recording and try to reestablish your Trellis-Trellis connection. If you manage to fix the Trellis-Trellis connection, the two instances will automatically re-synchronize and the Recording Synchronization form will turn green. If you cannot reestablish the Trellis-Trellis synchronization you must stop each recording manually, which will lead to the recordings having slightly different lengths.
- If the processor synchronization is interrupted (for example, due to the Processor Sync Cable becoming disconnected), the processors will stop sending data; the Recording Synchronization panel will change color to red, as shown in Figure 3-38; a dialog box will appear notifying the user that recording should be stopped; Trellis will emit a continuous warning beep to notify users who may not be attending at the File Save interface; the two-processor icon in the upper-right of the window will change to indicate a lost processor synchronization connection; the power light on each processor will flash alternately red then orange; and the processor front end port indicator LEDs will turn red to indicate a recording error. To re-enable two-processor synchronization, close all instances of Trellis, power down both processors, and check the Processor Sync Cable connections. If the physical connections appear to be intact, follow the initialization instructions presented earlier.

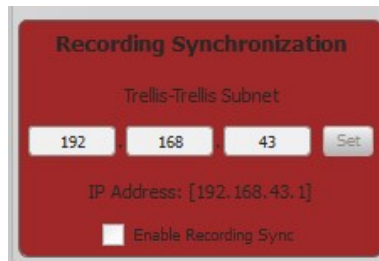

**Figure 3-38** Trellis File Save – Recording Synchronization cable error

# Technical Information



This appendix describes in detail the technical aspects of the Grapevine system. This appendix is not intended for use as a service or repair manual. Modification of any Grapevine components without the written permission of Ripple will void the warranty.

The Grapevine system consists of components that are designed to acquire hundreds of channels of biopotentials and other experimental data. The Grapevine NIP (PN: R00244) is a highly specialized, stand-alone computer system equipped with a 1.86 GHz Intel Core2Duo SL9400 Processor running a custom Linux kernel, along with 4 independent, medically isolated ports for connection to Front Ends (FEs). Up to 16 FEs can be connected to a NIP, and each type of FE is described in the following sections. All Grapevine FEs are powered by the Grapevine NIP through the Front End ports. All of the acquired signals are filtered, amplified, and sampled (digitized) within each FE. The information passed from the FEs to the NIP is in digital form, making the Grapevine system very resistant to environmental noise.

Data sent from the Grapevine system to a computer contains channel data sampled at a maximum of 30 kS/s. Data is transferred between the Grapevine NIP and the computer using User Datagram Protocol (UDP). UDP data is encoded using the eXtensible Instrument Processing Protocol (XIPP) format, a proprietary protocol developed at Ripple.

## Supported Front Ends

### Nano2, Nano2-HV, Nano2+Stim, and Nano2+Stim HC

PN: R02001 (Nano2), R02002 (Nano2-HV), R02003 (Nano2+Stim), R02014 (Nano2+Stim HC)

Size: 19 mm x 15 mm x 3.5 mm (LxWxD)

Weight: 2.0 g (Nano2), 3.5g (Nano2-HV, Nano2+Stim, and Nano2+Stim HC)

The Grapevine Nano2 FEs use a 4 guide post, 36-position Omnetics nanostrip connector (PN: A79023-001, mates with PN: A79022-001, A79024-001, or A79026-001 connectors) to interface with electrode platforms, using a pin configuration shown in Figure A-1 **Error! Reference source not found.** Because the Grapevine Nano2 FEs have high input impedance, they are suitable for connection to microelectrode arrays and other implanted electrodes. Acquired biopotential signals are first filtered using a high-pass filter that is user-controlled for the Nano2 (0.1 Hz default) and fixed at 1.0 Hz for the Nano2-HV, Nano2+Stim, and Nano2+Stim HC, followed by a low-pass filter with a 7.5 kHz cutoff. The Analog-to-Digital Converter (ADC) has 16-bit resolution and can be configured to be 0.125, 0.25 [default], or 0.5  $\mu\text{V/bit}$  resolution. The input range is  $\pm 4$ ,  $\pm 8$  ( $\pm 6$ ), or  $\pm 12$  ( $\pm 6$ ) mV, respectively. Parenthetical values represent the amplitudes above which some harmonic noise may occur. At the highest resolution setting (0.5  $\mu\text{V/bit}$ ), the linear range is  $\pm 12$  mV, though clipping will not occur until  $\pm 16$  mV. Each of the 32 channels are sampled at 30 kS/s. All recording electrode channels are referenced to a single reference electrode with selectable configurations (see Table 1-4). Note that G in the pinout configuration indicates the ground connections, and R1 and R2 indicate the Reference 1 and Reference 2 connections. The maximum safe input voltage is  $\pm 2.5$  V for the Nano2, and  $\pm 8.5$  V for the Nano2-HV, Nano2+Stim, and Nano2+Stim HC. The Nano2+Stim HC is similar to the Nano2+Stim and allows for additional charge induction. The Nano2-HV has additional circuitry for high-voltage protection in applications where nearby stimulation may occur. The Nano2 can measure electrode impedances



between 10 k $\Omega$  and 1 M $\Omega$  and the Nano2-HV and Nano2+Stim can measure impedances between 10 k $\Omega$  and 400 k $\Omega$ .

The Nano2+Stim FE is capable of delivering current-controlled stimulation on up to 32 independent electrodes with a range of up to  $\pm 1.5$  mA using  $\pm 100$  discrete current amplitude steps, and a compliance voltage of  $\pm 8.5$  V. The discrete current step-size can be configured to be 1, 2, 5, 10, or 20  $\mu$ A/step ( $\pm 75$  steps for the highest step-size). All stimulation is in reference to the ground connection. Stimulation and recording can be done simultaneously with the Nano2+Stim FE. The stimulation lookup table ensures the actual physical stimulation output of the FE matches the nominal output within defined tolerances. See the 'Instrument Configuration' section of Chapter 3 for more details on stimulation lookup tables.

### **Pico16+Stim, Pico16-HV, Pico32+Stim, Pico32-HV, Pico32**

PN: R03026 (Pico16+Stim), R03027 (Pico16-HV), R03028 (Pico32+Stim), R03029 (Pico32-HV), R03030 (Pico32)  
Size: 13.2 mm x 11.7 mm x 3.5 mm (LxWxD, Pico16+Stim, Pico16-HV)  
15.0 mm x 13.8 mm x 3.5 mm (LxWxD, Pico32)  
23.8 mm x 21.5 mm x 3.5 mm (LxWxD, Pico32+Stim, Pico32-HV)  
Weight: 0.8 g (Pico16+Stim, Pico16-HV), 1.1 g (Pico32), 2.2 g (Pico32+Stim, Pico32-HV)

The Grapevine Pico32 FEs use a 4 guide post, 36-position Omnetics nanostrip connector (PN: A79023-001, mates with PN: A79022-001, A79024-001, or A79026-001 connectors) to interface with electrode platforms, using a pin configuration shown in Figure A-1. Because the Grapevine Pico FEs have high input impedance, they are suitable for connection to microelectrode arrays and other implanted electrodes. Acquired biopotential signals are first filtered using a high-pass filter that is user-controlled for the Pico32 (0.1 Hz default) and fixed at 1.0 Hz for the other Pico variants, followed by a low-pass filter with a 7.5 kHz cutoff. The Analog-to-Digital Converter (ADC) has 16-bit resolution and can be configured to be 0.125, 0.25 [default], or 0.5  $\mu$ V/bit resolution. The input range is  $\pm 4$ ,  $\pm 8$  ( $\pm 6$ ), or  $\pm 12$  ( $\pm 6$ ) mV, respectively. Parenthetical values represent the amplitudes above which some harmonic noise may occur. At the highest resolution setting (0.5  $\mu$ V/bit), the linear range is  $\pm 12$  mV, though clipping will not occur until  $\pm 16$  mV. Each of the channels are sampled at 30 kS/s. All recording electrode channels are referenced to a single reference electrode and Pico32 FEs have selectable configurations (see Table 1-4). Note that G in the pinout configuration indicates the ground connections, and R1 and R2 indicate the Reference 1 and Reference 2 connections. The maximum safe input voltage is  $\pm 2.5$  V for the Pico32, and  $\pm 8.5$  V for the other Pico variants. The Pico16-HV and Pico32-HV have additional circuitry for high-voltage protection in applications where nearby stimulation may occur. The Pico32 can measure electrode impedances between 10 k $\Omega$  and 1 M $\Omega$  and the other Pico variants can measure impedances between 10 k $\Omega$  and 400 k $\Omega$ .

The Pico16+Stim is capable of delivering current-controlled stimulation on up to 16 independent channels with a range of up to  $\pm 1.0$  mA (1, 2, 5, or 10  $\mu$ A/step) and the Pico32+Stim is capable of delivering current-controlled stimulation on up to 32 independent electrodes with a range of up to  $\pm 1.5$  mA (1, 2, 5, 10, or 20  $\mu$ A/step). All stimulation is in reference to the ground connection. Stimulation and recording can be done simultaneously with Pico16+Stim and Pico32+Stim FEs. The stimulation lookup table ensures the actual physical stimulation output of the FE matches the nominal output within defined tolerances. See the 'Instrument Configuration' section of Chapter 3 for more details on stimulation lookup tables.

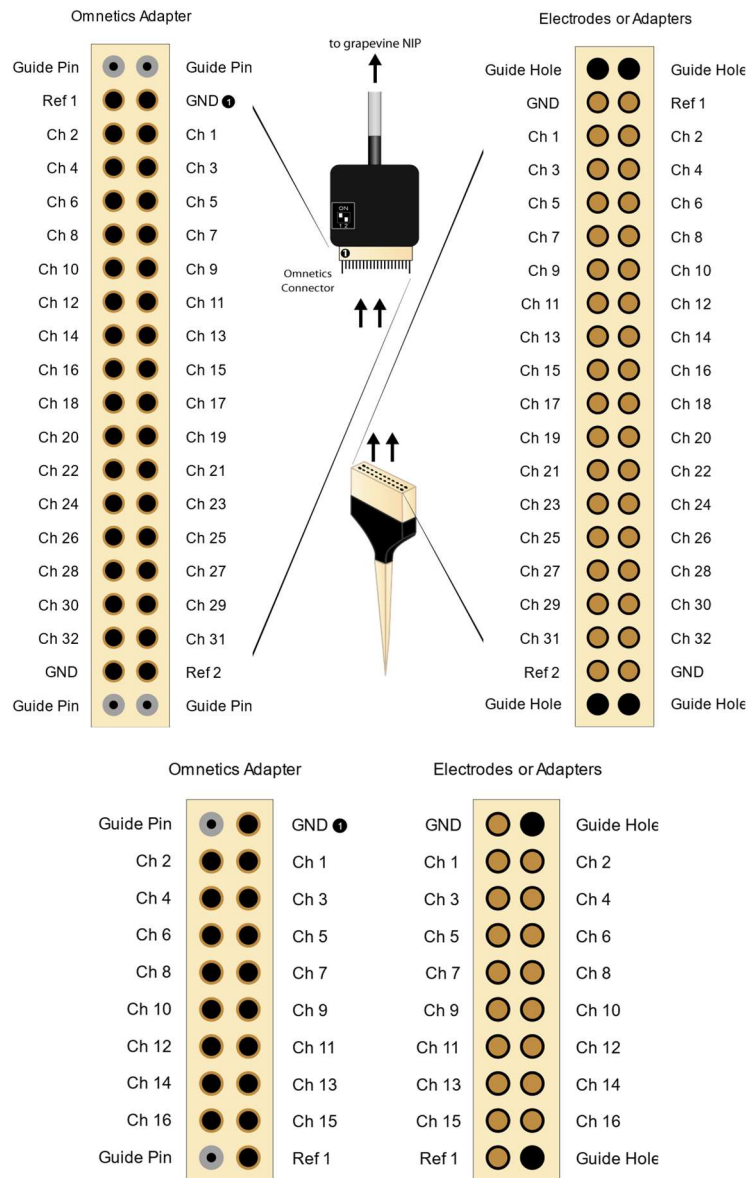

**Figure A-1** Grapevine Nano and Pico32 style FE pinout configuration (top), and Pico16 style FE pinout configuration (bottom).

**Note:** There is a known issue with the Stim variant FEs (excluding Micro+Stim) where simultaneous stimulation on multiple electrodes causes distortion in the stimulation output in the scenarios below. The solution to this is to use a higher stimulation step-size. For example, if you want to stimulate on 8 channels simultaneous at a level of 20  $\mu\text{A}$ , the recommended step-size would be 5  $\mu\text{A}/\text{step}$ . This issue only occurs during simultaneous stimulation across multiple electrodes, not during interleaved or off-set multiple electrode stimulation, and does not occur for the 20  $\mu\text{A}/\text{step}$  step-size.



Stimulation Step-Size ( $\mu\text{A}/\text{step}$ )	Number of Simultaneous Channels			
	2 or less	3-4	5-8	9 or more
1	$> 45 \mu\text{A}$	$> 20 \mu\text{A}$	$> 10 \mu\text{A}$	$> 5 \mu\text{A}$
2	$> 160 \mu\text{A}$	$> 60 \mu\text{A}$	$> 20 \mu\text{A}$	$> 10 \mu\text{A}$
5	no issue	$> 275 \mu\text{A}$	$> 25 \mu\text{A}$	$> 25 \mu\text{A}$
10	no issue	$> 1050 \mu\text{A}$	$> 500 \mu\text{A}$	$> 250 \mu\text{A}$

## Micro2, Micro2-HV, Micro2+Stim, and Micro2+Stim HC

PN: R02004 (Micro2), R02005 (Micro2-HV), R02006 (Micro2+Stim), R02016 (Micro2+Stim HC)

Size: 35 mm x 32 mm x 4.75 mm (LxWxD)

Weight: 9 g (Micro2), 9.5 g (Micro2-HV, Micro2+Stim, and Micro2+Stim HC)

The Grapevine Micro2, Micro2-HV, Micro2+Stim, and Micro2+Stim HC each use a 36-pin Samtec connector (PN: SFMC-118-L1-S-D, mates with Samtec FTS, FTSH, or TFM series connectors) to interface with electrode platforms, using a pin configuration shown in Figure A-2. Because the Grapevine Micro2 FEs have high input impedance, they are suitable for connection to microelectrode arrays and other implanted electrodes. Acquired biopotential signals are first filtered using a high-pass filter that is user-controlled for the Micro2 (0.1 Hz default) and fixed at 1.0 Hz for the Micro2-HV, Micro2+Stim, and Micro2+Stim HC, followed by a low-pass filter with a 7.5 kHz cutoff. The Analog-to-Digital Converter (ADC) has 16-bit resolution and can be configured to 0.125, 0.25 [default], or 0.5  $\mu\text{V}/\text{bit}$  resolution. The input range is  $\pm 4$ ,  $\pm 8$  ( $\pm 6$ ), or  $\pm 12$  ( $\pm 6$ ) mV, respectively. Parenthetical values represent the amplitudes above which some harmonic noise may occur. At the highest resolution setting (0.5  $\mu\text{V}/\text{bit}$ ), the linear range of data is only  $\pm 12$  mV, though clipping will not occur until  $\pm 16$  mV. Each of the 32 channels are sampled at 30 kS/s. All recording electrode channels are referenced to a single reference electrode with selectable configurations (see Table 1-4). Note that G in the pinout configuration indicates the ground connections, and R1 and R2 indicate the Reference 1 and Reference 2 connections. The maximum safe input voltage is  $\pm 2.5$  V for the Micro2, and  $\pm 8.5$  V for the Micro2-HV and Micro2+Stim. The Micro2-HV has additional circuitry for high-voltage protection in applications where nearby stimulation may occur.

The Micro2 can measure electrode impedances between 10 k $\Omega$  and 1 M $\Omega$  and the Micro2-HV and Micro2+Stim can measure impedances between 10 k $\Omega$  and 400 k $\Omega$ .

The Micro2+Stim FE is capable of delivering current-controlled stimulation on up to 32 independent electrodes with a range of up to  $\pm 1.5$  mA using  $\pm 100$  discrete current amplitude steps, and a compliance voltage of  $\pm 8.5$  V. The discrete current step-size can be configured to be 1, 2, 5, 10, or 20  $\mu\text{A}/\text{step}$  ( $\pm 75$  steps for the highest step-size). All stimulation is in reference to the ground connection. Stimulation and recording can be done simultaneously with the Micro2+Stim FE. The stimulation lookup table ensures the actual physical stimulation output of the FE matches the nominal output within defined tolerances. See the 'Instrument Configuration' section of Chapter 3 for more details on stimulation lookup tables.

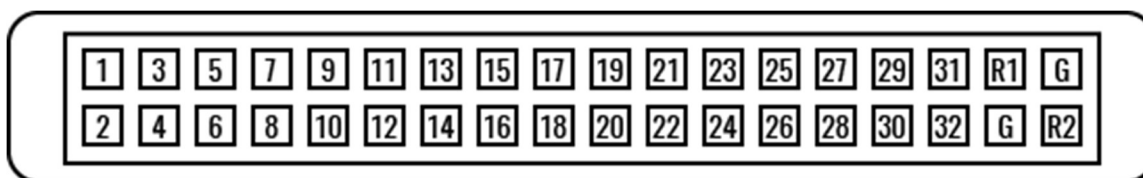

Figure A-2 Pinout configuration of the Grapevine Micro and Surf FEs

**Note:** There is a known issue with the Stim variant FEs (excluding Micro+Stim) where simultaneous stimulation on multiple electrodes causes distortion in the stimulation output in the scenarios below. The solution to this is to use a higher stimulation step-size. For example, if you want to stimulate on 8 channels simultaneous at a level of 20  $\mu\text{A}$ , the recommended step-size would be 5  $\mu\text{A}/\text{step}$ . This issue only occurs during simultaneous stimulation across multiple electrodes, not during interleaved or off-set multiple electrode stimulation, and does not occur for the 20  $\mu\text{A}/\text{step}$  step-size.

Stimulation Step-Size ( $\mu\text{A}/\text{step}$ )	Number of Simultaneous Channels			
	2 or less	3-4	5-8	9 or more
1	> 45 $\mu\text{A}$	> 20 $\mu\text{A}$	> 10 $\mu\text{A}$	> 5 $\mu\text{A}$
2	> 160 $\mu\text{A}$	> 60 $\mu\text{A}$	> 20 $\mu\text{A}$	> 10 $\mu\text{A}$
5	no issue	> 275 $\mu\text{A}$	> 25 $\mu\text{A}$	> 25 $\mu\text{A}$
10	no issue	> 1050 $\mu\text{A}$	> 500 $\mu\text{A}$	> 250 $\mu\text{A}$

### Explorer Macro+Stim

PN: R03008

The Explorer Macro+Stim uses a 42-pin Samtec connector (PN: SFMC-121-01-L-D, mates with Samtec FTS, FTSH, or TFM series connectors) to interface with electrode platforms using a pin configuration shown in Figure A-3. Acquired biopotential signals are filtered by a low-pass filter with a 2.0 kHz cutoff. The ADC of the Macro+Stim FE has 24-bit resolution with 0.022  $\mu\text{V}/\text{bit}$ , and an input range of  $\pm 187.5$  mV. Each channel is sampled at 7.5 kS/s and has an input impedance of 1.0  $\text{G}\Omega$  in parallel with 150 pF capacitance, with input referred noise of less than 1.0  $\mu\text{V}$  RMS. All recording electrode channels are referenced to a single reference electrode. Note that G in the pinout configuration indicates the ground connections, R indicates reference connections, and N/C indicates that the connection is not used.

The Macro+Stim can measure electrode impedances between 1  $\text{k}\Omega$  and 500  $\text{k}\Omega$ .

The Macro+Stim FE is capable of delivering current-controlled stimulation on one anode and one cathode per bank of 16 channels at any given time with a range of 100  $\mu\text{A}$  -15 mA using  $\pm 100$  discrete current amplitude steps, and a compliance voltage of  $\pm 30$  V. The discrete current step-size can be configured to be 10, 20, 50, 100, or 200  $\mu\text{A}/\text{step}$  ( $\pm 75$  steps for the highest step-size). All stimulation is in reference to the ground connection. Stimulation and recording can be done simultaneously.





## Explorer EEG

PN: R04002 (32-channel), R04003 (128-channel)

The Explorer EEG uses a 42-pin Samtec connector (PN: SFMC-121-01-L-D, mates with Samtec FTS, FTSH, or TFM series connectors) to interface with electrode platforms using a pin configuration shown in Figure A-3. The Explorer EEG FE is suitable for connection to low-impedance surface electrodes or head-affixed caps. Acquired biopotential signals are filtered by a low-pass filter with a 2.0 kHz cutoff. The ADC of the EEG FE has 24-bit resolution with 0.022  $\mu\text{V}/\text{bit}$ , and an input range of  $\pm 187.5\text{ mV}$ . Each channel is sampled at 7.5 kS/s has an input impedance of 1.0  $\text{G}\Omega$  in parallel with 20 pF capacitance, with input referred noise of less than 1.0  $\mu\text{V RMS}$ . All recording electrode channels are referenced to a single reference electrode. Note that G in the pinout configuration indicates the ground connections, R indicates reference connections, and N/C indicates that the connection is not used.

The EEG can measure electrode impedances between 1  $\text{k}\Omega$  and 500  $\text{k}\Omega$ .

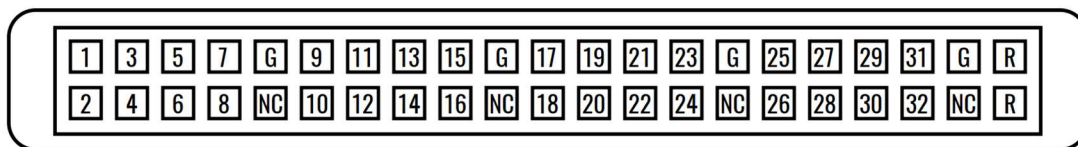

Figure A-3 Pinout configuration of the Explorer EEG and Macro FEs

## Link 32

PN: R02045 (transceiver), R01884 (implant)

Size: 41 mm x 8.25 mm (transceiver, ODxH), 31 mm x 23 mm x 6 mm (implant, LxWxD)

Weight: 23 g (transceiver), 10.5 g (implant)

The Grapevine Link 32 Front End consists of an implant and disk-shaped transceiver. The implant is similar in size to a Nano2+Stim FE and is powered by resonant inductive coupling through the transceiver. Data streams are transmitted from the implant to the transceiver wirelessly through IR at 2.0 kS/s. The ADC of the implant has 12-bit resolution with 4.0  $\mu\text{V}/\text{bit}$ . The input range is  $\pm 8\text{ mV}$  with a maximum safe input voltage of  $\pm 2.5\text{ V}$ .

## EMG

PN: R02008

Size: 51.5 mm x 36.5 mm x 4.75 mm (LxWxD)

Weight: 12.5 g

The Grapevine EMG uses a 36-pin Samtec connector (PN: SFMC-118-L1-S-D, mates with Samtec FTS, FTSH, or TFM series connectors) to interface with electrode platforms using a pin configuration shown in Figure A-4 below. The Grapevine EMG is suitable for connection to all low-impedance differential surface and implanted electrodes. The ADC of the EMG FE has 24-bit resolution with 0.022  $\mu\text{V}/\text{bit}$ , and an input range of  $\pm 187.5\text{ mV}$ . The maximum safe input voltage is  $\pm 4.5\text{ V}$ . Each channel of the EMG is sampled at 7.5 kS/s and has an input impedance of 1.0  $\text{G}\Omega$  in parallel with 20 pF capacitance, with input referred noise of less than 1.0  $\mu\text{V RMS}$ . Note that G indicates the ground sockets and N/C indicates that the socket is not used.

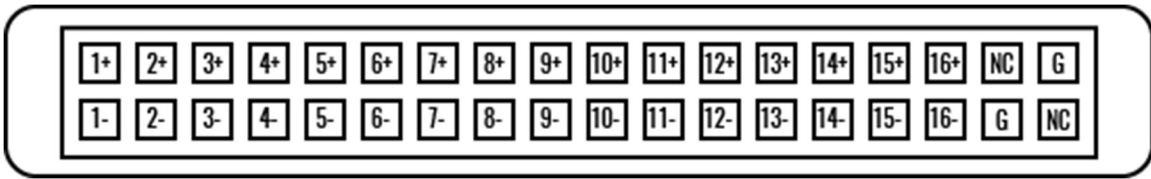

Figure A-4 Pinout configuration of the Grapevine EMG

## Digital I/O

PN: R00591  
Size: 105 mm x 60 mm x 14 mm (LxWxD)  
Weight: 90 g

### Digital Inputs

The Grapevine Digital I/O FE (DIO, PN: R00591) is capable of recording up to 20 digital inputs. On the left side of the DIO are 4 SMA connectors and a single 25-pin Micro-D connector for parallel digital input use. Each SMA connector can receive a single channel of digital input, whereas the Micro-D connector can receive 16 bits of digital input. The remaining pins provide ground connections and Strobe synchronization. Details of the pinout configuration can be found below in Figure A-5.

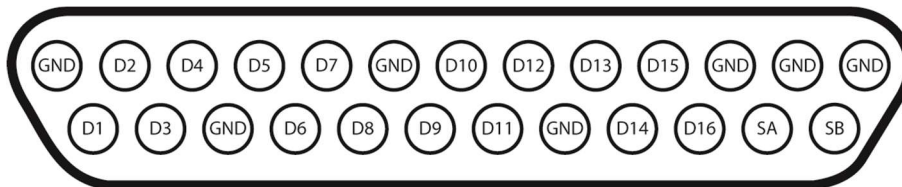

Figure A-5 Pinout configuration of the Grapevine Digital I/O Micro-D connector

**Note:** SA and SB stand for Strobe A and Strobe B respectively.

By default, the 16-bit parallel port state is only captured when either Strobe A or Strobe B is set high. The setting can be changed in either Trellis or by using Xippmex, so that the 16-bit parallel port state is captured when there is a bit change on any of the parallel port lines. The DIO uses LVTTTL for signal transmission, meaning that a “low” voltage, or 0 bit, is from 0 V to 0.8 V, whereas a “high” voltage, or 1 bit, is from 2 V to 3.3 V. **Note:** The DIO can handle up to 5 V inputs. In order to be recognized by the system, digital input events must span at least 2 clock cycles; i.e., a bit must be low or high for at least 67  $\mu$ s. The digital inputs have an impedance of >10 M $\Omega$  and are sampled at 10 kS/s.

### Digital Outputs

The DIO can produce up to 20 digital outputs. Using the Trellis software, spike events can be configured to trigger a LVTTTL pulse on a digital output channel. On the right side of the DIO are 4 SMA connectors and a single 25-pin Micro-D connector for output use. Each SMA connector provides a single channel of digital output, whereas the Micro-D connector provides 16 bits of digital output. The remaining pins are used for ground connections and Strobe synchronization. Details of the pinout configuration can be found in Figure A-5 above (same configuration as Digital I/O input). The DIO uses LVTTTL for signal transmission (0/3.3 V). The digital outputs have an impedance of 2 k $\Omega$  and are produced at 10 kS/s. See the ‘Instruments > Digital Outputs’ section of Chapter 3 for detailed information on digital output event markers.



## Analog I/O

PN: R00407  
Size: 105 mm x 75 mm x 14 mm (LxWxD)  
Weight: 100 g

### Analog Inputs

The Grapevine Analog I/O FE (AIO, PN: R00407) is capable of recording up to 28 analog inputs. On the left side of the AIO are 4 SMA connectors and a single 25-pin Micro-D connector for input use. Each SMA connector can receive a single channel of analog input connection, whereas the Micro-D connector can receive 24 channels of analog input. The remaining pin provides a ground connection. Details of the pinout can be found below in Figure A-6. The AIO inputs are sampled at 1 kS/s and/or 30 kS/s and have an impedance of 10 M $\Omega$ . The ADC on the analog inputs has a 16-bit resolution and a range of  $\pm 5$  V (0.15 mV/bit).

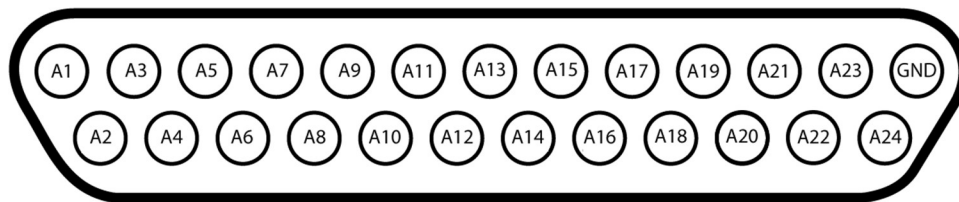

Figure A-6 Pinout configuration of the Grapevine Analog I/O Micro-D connector

### Analog Outputs

The AIO can produce up to 28 analog outputs. Using the Trellis software, input signals from any FE can be reproduced on any of the analog outputs. On the right side of the AIO, there are 4 SMA connectors and a single 25-pin Micro-D connector for output use. Each SMA connector provides a single channel of analog output, whereas the Micro-D connector provides 24 channels of analog output. The remaining pin is used for a common ground connection. Details of the pinout configuration can be found above in Figure A-6 (same configuration as Analog I/O input). The analog outputs can produce signals within a  $\pm 5$  V range with 16-bit resolution (0.15 mV steps). The analog outputs have an impedance of 5.5 k $\Omega$  and are produced at 10 kS/s, except for the audio outputs which have an impedance of 1 k $\Omega$ . Contact Ripple if custom analog output configurations are needed. See the 'Instruments > Analog Outputs' section of Chapter 3 for detailed information on analog output routing of continuous data streams.

### Audio Ports

There are two 3.5 mm stereo audio output ports and one stereo audio input port on the AIO. The audio input port can be used to capture data with a  $\pm 5$  V range. The audio output ports can be configured to reproduce data captured from other FEs, such as spiking activity, to be played from speakers.



## Analog+Digital I/O

PN: R02010  
Size: 100 mm x 75 mm x 22 mm (LxWxD)  
Weight: 110 g

The Grapevine Analog+Digital I/O FE (ADIO, PN: R02010) combines the analog capabilities of the AIO with the digital capabilities of the DIO in a single Front End.

### Analog Inputs

The ADIO can record up to 4 analog inputs. On the left side of the ADIO are 4 SMA connectors and each connector can receive a single channel of analog input. The ADIO analog inputs are sampled at 1 kS/s and/or 30 kS/s and have an impedance of 10 M $\Omega$ . The ADC on the analog inputs has a 16-bit resolution and a range of  $\pm 5$  V (0.15 mV/bit).

### Analog Outputs

The ADIO can produce up to 4 analog outputs. Using the Trellis software, input signals from any FE can be reproduced on any of the analog outputs. On the right side of the ADIO, there are 4 SMA connectors for output use and each SMA connector provides a single channel of analog output. The analog outputs can produce signals within a  $\pm 5$  V range with 16-bit resolution (0.15 mV steps). The analog outputs have an impedance of 5.5 k $\Omega$  and are produced at 10 kS/s, except for the audio outputs which have an impedance of 1 k $\Omega$ . Contact Ripple if custom analog output configurations are needed. See the ‘Instruments > Analog Outputs’ section of Chapter 3 for detailed information on analog output routing of continuous data streams.

### Audio Ports

There are two 3.5 mm stereo audio ports on the ADIO, one for input and one for output. The audio input port can be used to capture analog data with a  $\pm 5$  V range. The audio output port can be configured to reproduce data captured from other FEs, such as spiking activity, to be played from speakers.

### Digital Inputs

The ADIO can record up to 20 digital inputs. On the left side of the ADIO are 4 SMA connectors and a single 25-pin Micro-D connector for parallel digital input use. Each SMA connector can receive a single channel of digital input, whereas the Micro-D connector can receive 16 bits of digital input. The remaining pins provide ground connections and Strobe synchronization. Details of the pinout configuration can be found in Figure A-5. By default, the 16-bit parallel port state is only captured when either Strobe A or Strobe B is set high. The setting can be changed in either Trellis or by using Xippmex, so that the 16-bit parallel port state is captured when there is a bit change on any of the parallel port lines.

The ADIO uses LVTTTL for signal transmission, meaning that a “low” voltage, or 0 bit, is from 0 V to 0.8 V, whereas a “high” voltage, or 1 bit, is from 2 V to 3.3 V. **Note:** The ADIO can handle up to 5 V inputs. In order to be recognized by the system, digital input events must span at least 2 clock cycles; i.e., a bit must be low or high for at least 67  $\mu$ s. The digital inputs have an impedance of  $>10$  M $\Omega$  and are sampled at 10 kS/s.



## Digital Outputs

The ADIO can produce up to 20 digital outputs. Using the Trellis software, spike events can be configured to trigger a LVTTTL pulse on a digital output channel. On the right side of the ADIO are 4 SMA connectors and a single 25-pin Micro-D connector for output use. Each SMA connector provides a single channel of digital output, whereas the Micro-D connector provides 16 bits of digital output. The remaining pins are used for ground connections and Strobe synchronization. Details of the pinout configuration can be found in Figure A-5 (same configuration as Digital I/O input). The ADIO uses LVTTTL for signal transmission (0/3.3 V). The digital outputs have an impedance of 2 k $\Omega$  and are produced at 10 kS/s. See the ‘Instruments > Digital Outputs’ section of Chapter 3 for detailed information on digital output event markers.

## Legacy Front Ends

**Note: Legacy FEs can still be used with all Grapevine processors and Ripple Software applications unless otherwise noted.**

### Nano

PN: R00894 (Nano)  
Size: 31.75 mm x 13.25 mm x 3.5 mm (LxWxD)  
Weight: 3.5 g

The Grapevine Nano uses a 4 guide post, 36-position Omnetics nanostrip connector (PN: A79023-001, mates with PN: A79022-001, A79024-001, or A79026-001 connectors) to interface with electrode platforms, using a pin configuration shown in Figure A-1. Because the Grapevine Nano has high input impedance, it is suitable for connection to microelectrode arrays and other implanted electrodes. To minimize the weight and for small animal use, the Nano does not have secondary isolation circuits or shielding. Acquired biopotential signals are first filtered in hardware through a high-pass filter with a 0.3 Hz cutoff and low-pass filter with a 7.5 kHz cutoff. The ADC has 16-bit resolution with 0.2  $\mu$ V/bit, and an input range of  $\pm 5$  mV. Each channel is sampled at 30 kS/s and has an input impedance of 450 M $\Omega$  in parallel with 15 pF capacitance, with input referred noise of less than 2.1  $\mu$ V RMS. All recording electrode channels are referenced to a single reference electrode with selectable configurations (see Table 1-4). Note that G in the pinout configuration indicates the ground connections, and R1 and R2 indicate the Reference 1 and Reference 2 connections. The maximum safe input voltage is  $\pm 5$  V. The Nano can measure electrode impedances between 10 k $\Omega$  and 1 M $\Omega$ .

**Note: The Grapevine Nano is not intended for clinical or research use with humans.**

### Micro, Micro-HV, and Micro+Stim

PN: R00249 (Micro), R01425 (Micro-HV), R00408 (Micro+Stim)  
Size: 51.5 mm x 36.5 mm x 4.75 mm (LxWxD)  
Weight: 12.5 g (Micro), 13.5 g (Micro-HV and Micro+Stim)

The Grapevine Micro, Micro-HV, and Micro+Stim use a 36-pin Samtec connector (PN: SFMC-118-L1-S-D, mates with Samtec FTS, FTSH, or TFM series connectors) to interface with electrode platforms, using a pin configuration shown in Figure A-2. Because the Grapevine Micro, Micro-HV, and Micro+Stim have high input impedance, they are suitable for connection to microelectrode arrays and other implanted electrodes. Acquired signals are first filtered using a high-pass filter with a 0.3 Hz cutoff and low-pass filter with a 7.5 kHz cutoff. The ADC has 16-bit resolution with



0.2  $\mu\text{V}/\text{bit}$ , and an input range of  $\pm 5$  mV. Each channel is sampled at 30 kS/s and has an input impedance of 450 M $\Omega$  in parallel with 15 pF capacitance, with input referred noise of less than 2.1  $\mu\text{V}$  RMS. All recording electrode channels are referenced to a single reference electrode with selectable configurations (see Table 1-4). Note that G in the pinout configuration indicates the ground connections, and R1 and R2 indicate the Reference 1 and Reference 2 connections. The maximum safe input voltage is  $\pm 5$  V. The Micro can measure electrode impedances between 10 k $\Omega$  and 1 M $\Omega$ . The Micro-HV has additional circuitry for high-voltage protection in applications where nearby stimulation may occur.

The Micro+Stim FE is capable of delivering current-controlled stimulation on up to 32 independent electrodes with a range of  $\pm 0.75$  mA using  $\pm 100$  discrete steps of 7.5  $\mu\text{A}$ , and a compliance voltage of  $\pm 9$  V. All stimulation is in reference to the ground connection. Stimulation and recording can be done simultaneously with the Micro+Stim FE.

## Surf S2

PN: R02015  
Size: 30 mm x 26 mm x 4.75 mm (LxWxD)  
Weight: 9 g

The Grapevine Surf S2 uses a 36-pin Samtec connector (PN: SFMC-118-L1-S-D, mates with Samtec FTS, FTSH, or TFM series connectors) to interface with electrode platforms, using a pin configuration as shown in Figure A-2. Because the Grapevine Surf S2 has high input impedance, it is suitable for all surface electrodes. Acquired biopotential signals are first filtered using a high-pass filter that is user-controlled (0.1 Hz default) followed by a low-pass filter with a 7.5 kHz cutoff. The Analog-to-Digital Converter (ADC) has 16-bit resolution and can be configured to 0.125, 0.25 [default], or 0.5  $\mu\text{V}/\text{bit}$  resolution. The input range is  $\pm 4$ ,  $\pm 8$  ( $\pm 6$ ), or  $\pm 12$  ( $\pm 6$ ) mV, respectively. Parenthetical values represent the amplitudes above which some harmonic noise may occur. At the highest resolution setting (0.5  $\mu\text{V}/\text{bit}$ ), the linear range of data is only  $\pm 12$  mV, though clipping will not occur until  $\pm 16$  mV. Each of the 32 channels are sampled at 30 kS/s. All recording electrode channels are referenced to a single reference electrode with selectable configurations (see Table 1-4). Note that G in the pinout configuration indicates the ground connections, and R1 and R2 indicate the Reference 1 and Reference 2 connections. The maximum safe input voltage is  $\pm 2.5$  V.

## Surf S

PN: R00318  
Size: 51.5 mm x 36.5 mm x 4.75 mm (LxWxD)  
Weight: 12.5 g

The Grapevine Surf S uses a 36-pin Samtec connector (PN: SFMC-118-L1-S-D, mates with Samtec FTS, FTSH, or TFM series connectors) to interface with electrode platforms, using a pin configuration as shown in Figure A-2. Because the Grapevine Surf S has high input impedance, it is suitable for all surface electrodes. Biopotential recordings are first filtered in hardware through a high-pass filter with a 0.3 Hz cutoff and low-pass filter with a 7.5-kHz cutoff. The ADC has 16-bit resolution with 0.2  $\mu\text{V}/\text{bit}$ , and an input range of  $\pm 5$  mV. Each channel is sampled at 30 kS/s and has an input impedance of 450 M $\Omega$  in parallel with 15 pF capacitance, with input referred noise of less than 2.1  $\mu\text{V}$  RMS. All recording electrode channels are referenced to a single reference electrode with selectable configurations (see Table 1-4). Note that G in the pinout configuration indicates the ground connections, and R1 and R2 indicate the Reference 1 and Reference 2 connections.



---

## Surf D

The Grapevine Surf D (PN: R00263) uses a 36-pin Samtec connector (PN: SFMC-118-L1-S-D, mates with Samtec FTS, FTSH, or TFM series connectors) to interface with electrode platforms, using the same pin configuration as the EMG, shown in Figure A-3. Because the Grapevine Surf D has high input impedance, it is suitable for connection to all differential surface electrodes. Differential biopotential recordings are first filtered in hardware in the Grapevine Surf D through a high-pass filter with a 0.3 Hz cutoff and low-pass filter with a 7.5-kHz cutoff. The ADC of the Surf D FE has 16-bit resolution with 0.25  $\mu\text{V/bit}$ , and an input range of  $\pm 6.5\text{ mV}$ . Each channel of the Surf D is sampled at 30 kS/s and has an input impedance of 250 M $\Omega$  in parallel with 20 pF, with input referred noise of less than 2.1  $\mu\text{V RMS}$ . Note that G indicates the ground sockets and N/C indicates that the socket is not used.

# System Information



This appendix describes in detail how to access the hardware information for the Grapevine processor and Front Ends, as well as system information for the Trellis software suite. This information will be useful if problems arise and there is a need to contact support engineers at Ripple. Current Trellis software for a desired operating system platform can be downloaded from the Ripple [website](#). The firmware for the Grapevine processors and Front Ends is programmed at the time of production; however, the processor firmware can be updated. When new versions of the processor firmware are completed by the developers, a support engineer will be in contact and details on how to update the Grapevine processor will be provided.

## Trellis Software

The Trellis software information can be found by running Trellis and clicking on the Trellis icon in the upper left, as shown in Figure B-1 below. This will then open a new window containing information about the software, including the build number in bold at the top, as well as the build date and source revisions, as can be seen below in Figure B-2.

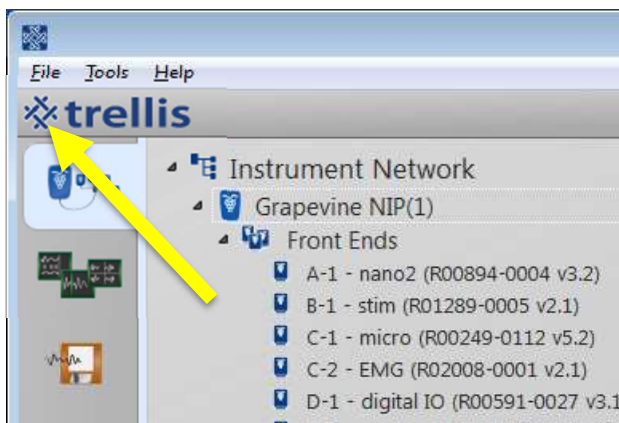

**Figure B-1** Accessing the Trellis software suite information

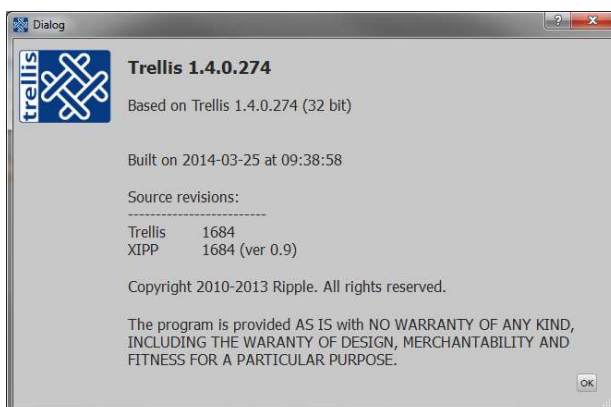

**Figure B-2** Trellis software suite information





## Grapevine Processors and Front Ends

The hardware information for the Grapevine processor and Front Ends can be found by using Trellis. Make sure all FEs are plugged into the Grapevine processor before turning on the power. Run the Trellis software, and if everything is configured correctly, the display screen should look similar to Figure B-3 and Figure B-4 below, showing the Instrument Network and the attached Grapevine NIP. To access the properties for the NIP, right click on the Grapevine NIP item, under the Instrument Network on the left side of the window, and select Show Properties, as shown in Figure B-4 below.

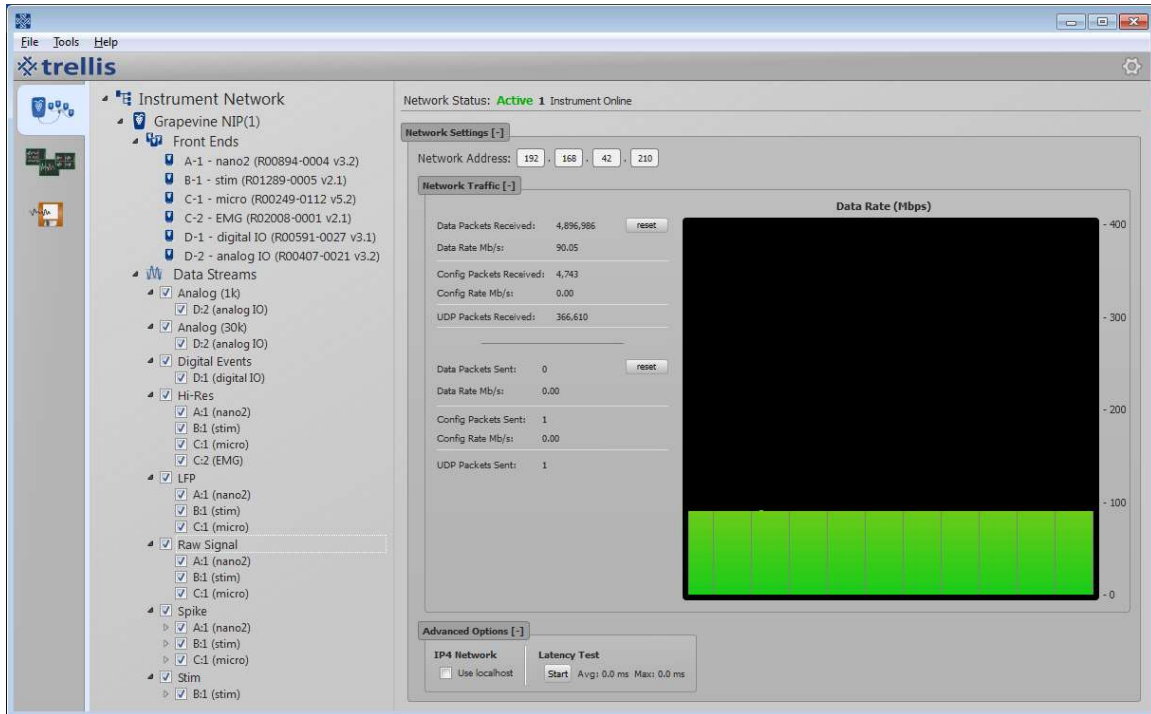

Figure B-3 Instrument Network

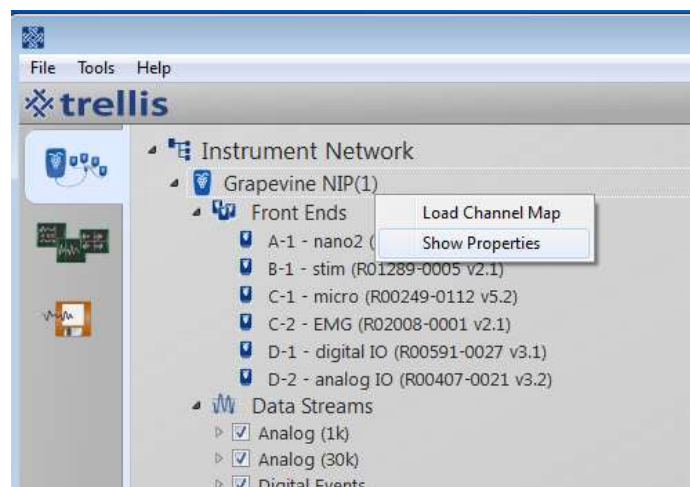
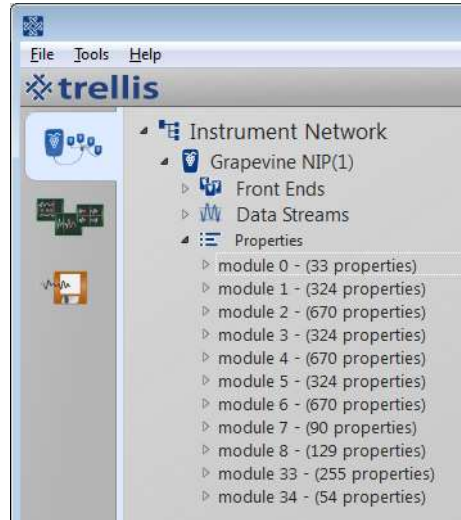

Figure B-4 Accessing Grapevine NIP properties



This will enable the display of all properties of the NIP and connected FEs as individual modules, as shown in Figure B-5 below. The first module, module 0, is the Grapevine NIP. The Grapevine Front End amplifiers will be listed as modules 1-32, with 2 consecutive modules listed for each FE. The Grapevine Analog and Digital I/O FEs begin at module 33. The properties of the NIP and all connected FEs, including the hardware version, can be found by clicking on the module, as shown in Figure B-6 through Figure B-8.



**Figure B-5** Modules of the Grapevine NIP and FEs  
Modules 1 and 2 shown here are for a single Nano2 Front End, Nano2+Stim (3&4), Micro (5&6), EMG (7&8), AIO (33), and DIO (34)

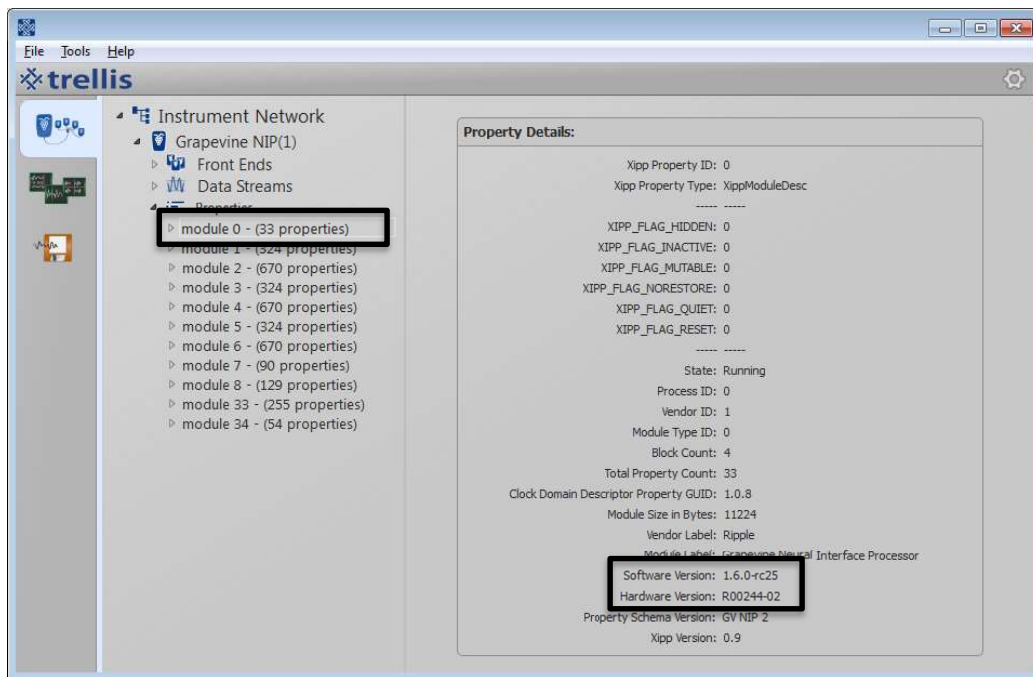

**Figure B-6** Module 0 – Grapevine processor information

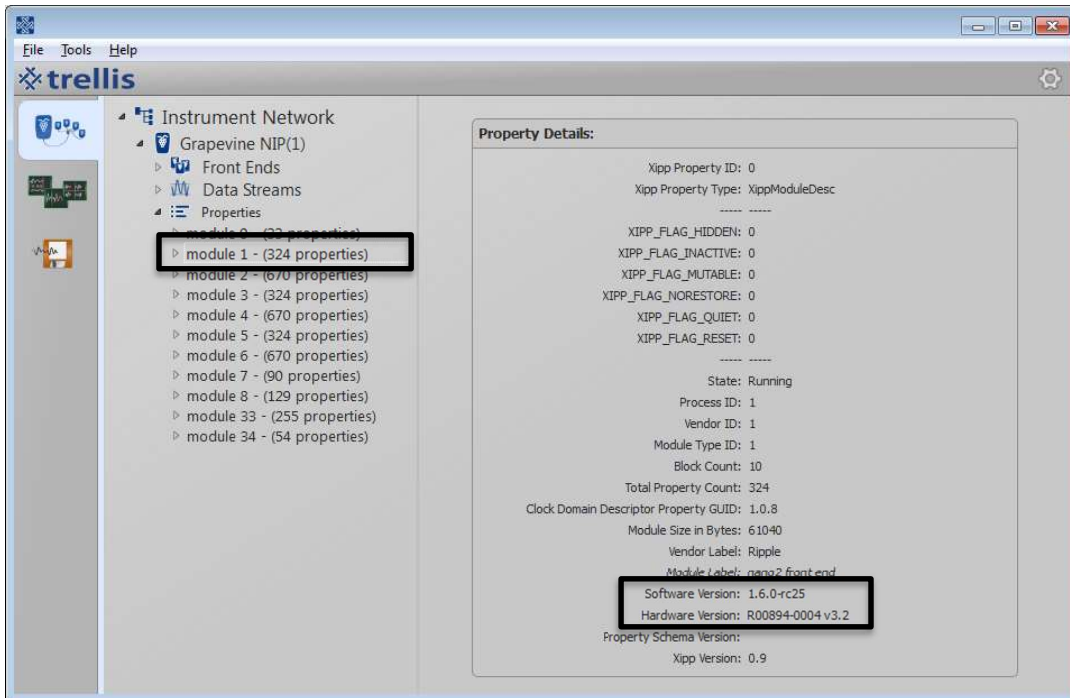

Figure B-7 Modules 1-32 – Front End amplifier information

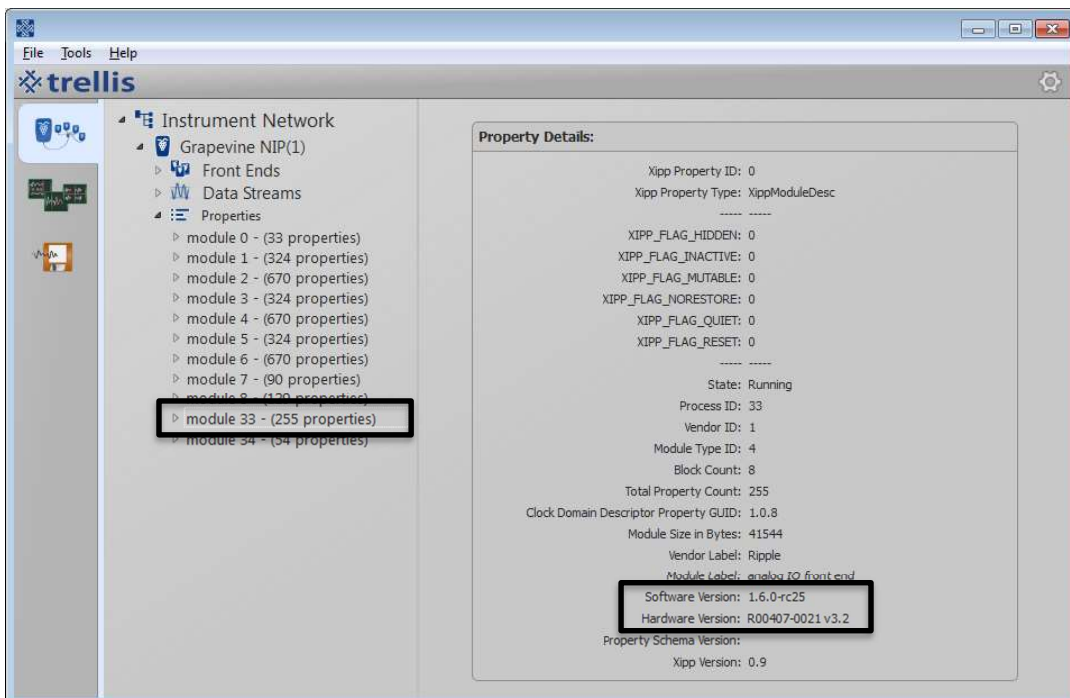

Figure B-8 Modules 33 and 34 – Analog I/O (shown) and Digital I/O Front End information



---

## Appendix C

# Hardware & Software Configuration

---

This appendix describes the startup states of the neural processors, Front Ends (FEs), and Trellis, as well as what information is saved in the Trellis Configuration File. Each component of the Grapevine Neural Interface System has a default startup state that is set when the system is powered on. These hardware and software states can be changed to user-desired configurations by loading a Trellis configuration file.

## Hardware

Below are the default startup states that are specific to the neural processors and Front Ends and will be shown as such in the main Trellis program. All of the hardware settings below are dependent on which Front Ends are connected to the system. These states can be changed in the active system through Trellis, Xippmex, or user-developed C++ applications. All of the below hardware states will be reset to default when the processor is powered off and on.

- Data Streams
  - LFP: On
  - Hi-Res: On
  - Raw: Off
  - Spike: On
  - Stim: On
  - Analog (1k): Off
  - Analog (30k): On
  - Digital Events: On
  
- Global Thresholding
  - Method: Multiple of RMS (Median)
  - How to Apply: Single Only
  - Level: -5.0  $\mu$ V
  - Spike Sorting: Disabled
  
- Digital I/O Options
  - Loopback UDP-triggered digital output: On
  - Capture digital input on parallel bit change: Off
  
- Analog Outputs
  - Enable: Off
  - Source Channel: Off
  - Signal Type: Off
  
- Digital Outputs
  - Enable: Off

- Source Channel: Off
- Signal Type: Off
  
- Fast Settle Triggers
  - Digital Inputs: None, When High, 0.5 ms
  - Stim: Any Front End, 0.5 ms
  - Auto: Off
  
- DSP Filter Settings
  - Hi-Res Filter
    - 0.3-500 Hz – Micro, Micro-HV, Micro+Stim, Nano, EMG, Surf S
    - 0.1-500 Hz – Nano2
  - Hi-Res Notch Filter: Off
  - LFP Filter
    - 0.3-250 Hz – Micro, Micro-HV, Micro+Stim, Nano, Surf S
    - 0.1-250 Hz – Nano2
  - LFP Notch Filter: Off
  - Spike Filter: 250-7500 Hz – Micro, Micro-HV, Micro+Stim, Nano, Nano2
  
- Front End Hardware
  - High-Pass Filter: 0.1-Hz (Micro2 and Nano2 only)
  - Recording Resolution: 0.25  $\mu$ V/bit ( $\pm$  8 mV range)

## Trellis Software Suite

Below are the default startup states that are specific to the Trellis Applications. Some of the settings below are dependent on which Front Ends are connected to the system. Some of the Trellis settings can be considered “sticky” and will be set at startup based on what was used during the last Trellis session.

- Trellis Main - Instruments
  - Analog Outputs
    - Tracking: Off
  - Digital Outputs
    - Tracking: Off
  
- Application Auto-Restore – The Raster, Spike Grid, Spike Scope, and Impedance Analyzer Applications have the ability to auto-restore all their settings from the last session through the ‘Tools>Options’ menu in the top menu bar.
  
- Raster – If restore is not enabled
  - Data Streams
    - LFP: On
    - Hi-Res: On
    - Raw: On
    - Spike: On
    - Spike Preview: Off
    - Stim: On
    - Analog (1k): On
    - Analog (30k): On
    - Digital Events: On



- Colors: **Off**
  - Signals: Grouped by Data Stream
- Spike Grid – If restore is not enabled
  - Heat Map: **Off**
  - Scale: 200  $\mu$ V
  - Hold: 50 Spikes
  - Electrode Map: Unloaded
- Stimulation Controller
  - When the Stimulation Controller App is relaunched, the last electrode(s) selected during the previous sessions will again be selected and active in the Waveform, Period, and Train displays.
- File Save - defaults
  - Data Streams – based on which Data Streams are enabled in Instruments
    - LFP: On
    - Hi-Res: On
    - Raw: **Off**
    - Spike: On
    - Stim: On
    - Analog (1k): On
    - Analog (30k): **Off**
    - Digital Events: On
  - Digital Triggering: **Off**
  - File Save Name\Location: <homeDir>\Trellis\dataFiles\<date>\datafile
- File Save – sticky settings loaded based on last Trellis session
  - Data Streams and Individual Channels
  - Auto Increment
  - Stop After
  - Save Instrument Configuration
  - Segment Recording Every
  - Play Tone on Start/Stop
  - Enable Remote Control

## Trellis Configuration File

The Trellis Configuration File contains saved settings for both the Grapevine system hardware and Trellis software. This Configuration file can be saved through either the main Trellis Instruments program or the File Save Application, and can be restored through the main Trellis Instruments program. Besides storing all of the above hardware and software settings, the Trellis Configuration File also contains information about per-channel single-unit spike sporting, Application window sizes, locations, and Trellis main options such as notification selections and color scheme.



# Additional Software Components

---

## **MATLAB®**

Ripple has developed an online MATLAB® interface to Trellis and the Grapevine processor called Xippmex. This software enables instrumentation configuration of the Grapevine processor and near real-time access to data streams and stimulation output, as well as control of recording with Trellis. Ripple is currently providing this code in a beta version that fulfills a subset of the capabilities. Xippmex is located in the installed directory ‘...\Ripple\Trellis\Tools\xippmex’. Examples on how to use the software components can be found in the Xippmex user manual, located in the Trellis document directory at ‘...\Ripple\Trellis\Documentation\xippmex’.

## **Open Source MATLAB®**

Ripple provides open source offline MATLAB® functionality with the Trellis software suite. These interfaces, functions, and associated examples can be found in the installed directory, ‘...\Ripple\Trellis\Tools’ and can be tested with a sample saved data set, that includes spikes, LFP, Hi-Res, raw, stim, digital input, and analog input data, which can be downloaded from the [website](#).

### *Neuroshare*

Inside the Tools directory is a directory labeled ‘neuroshare’ containing a set of functions based on the open source Neuroshare API. These functions can be used to extract digital and analog data that are acquired from any of the Front Ends, along with additional information such as event timing, hardware information, and channel configuration. There are a number of example scripts in the ‘neuroshare\examples’ directory that will demonstrate how to properly extract and plot common data types such as spike waveforms, spike histograms, and continuous analog data.

### *Wisteria*

The Wisteria Offline Data Viewer displays data that is saved by the Trellis software, in a manner similar to the Raster Application, and can be found in the Tools directory, ‘...\Tools\wisteria’. The viewer can be run by including the wisteria and neuroshare directories in the path or by setting the working directory to be ‘...\Tools\wisteria’, and then running ‘wisteria’ from the command window. To load a data file, select ‘File > Open’ and then navigate to the saved data file. The toolbar buttons in Wisteria control which channels are viewed and what the plot scaling is, similar to the buttons found in the Raster Application of Trellis. Additional data file information can be found from ‘File > File Info’.

### *MKsort*

MKsort is an offline spike sorter created by Matt Kaufman while he was at Stanford University. This software enables users to import electrophysiological data and classify waveforms as coming from different units ("sort spikes"). It also provides tools for examining the stability of these isolations over time, rating the isolations, measuring spike widths, and examining the functional tuning of the sorted units. The main function, ‘mksort.m’, and the complete set of functions can be found in the ‘...\Tools\mksort’ directory. A walkthrough document using example data is provided in the ‘...\Tools\mksort\docs’ directory. This tool may be found online as well ([github link](#)).



## Python

Ripple provides offline Python functionality that is included with the Trellis software suite. Inside the Tools directory is a directory labeled 'pyns' containing a set of functions and classes based on the open source Neuroshare API, which can be used to extract digital and analog data acquired from any of the Front Ends. Example command line Python functions can be found in the '...\pyns\examples' directory. Complete documentation on installation, examples, and module definitions can be found in the pyns.pdf file in the '...\Trellis\Documentation\pyns' directory.

## C

A set of C headers for writing custom programs to control the Grapevine NIP are included with the Trellis software suite in the '...\Tools\xippmin' directory. These headers may be useful for applications requiring low-latency access to data acquired by the Grapevine NIP. There are also some example programs in the xippmin directory for triggering Trellis and reading the data streams produced by the Grapevine NIP.

## Third-Party Software Compatibility

Ripple provides a Neuroshare dynamic-link library (nsNEVLibrary.dll) for use with third-party software to import files saved by Trellis. The library file is included in the Trellis software suite in both 32-bit (x86) and 64-bit (x64) versions, and can be found in the '...\Trellis\Tools\thirdparty' directory. **Note:** Use of these files currently requires the installation of Visual C++ Redistributable for Visual Studio 2012. This package may be found [here](#) and is available in x86 and x64 versions.

### *Nex Technologies NeuroExplorer®*

The NeuroExplorer program must first be configured by going to 'View > Data Import Options > Blackrock Microsystems Files', selecting 'Use Neuroshare DLL', and pointing the 'Neuroshare DLL Path' to the correct '...\Trellis\Tools\thirdparty\nsNEVLibrary\xXX\nsNEVLibrary.dll' path. Files can then be imported into NeuroExplorer as Blackrock Microsystems files. **Note:** Use of these DLL files currently requires the installation of Visual C++ Redistributable for Visual Studio 2012. This package may be found [here](#) and is available in x86 and x64 versions.

### *Plexon® Offline Sorter™*

The Offline Sorter program must first be configured by going to 'Tools > Data Import Options > Cyberkinetics (or Blackrock in v4.1)', selecting 'Use Neuroshare Loader', and pointing the 'Neuroshare DLL Location' to the correct '...\Trellis\Tools\thirdparty\nsNEVLibrary\xXX\nsNEVLibrary.dll' path. Files can then be imported into Offline Sorter as Cyberkinetics Files (or Blackrock Files in v4.1). **Note:** Use of these DLLs currently requires the installation of Visual C++ Redistributable for Visual Studio 2012. This package may be found [here](#) and is available in x86 and x64 versions.



# Adapters



Ripple provides adapters that connect Grapevine Front Ends to all passive electrodes and electrode arrays, as well as adapters for recording and stimulation testing purposes. Some of the common Front End adapters are described below along with figures showing how the cables, adapters, and FEs connect together. Custom adapters that connect Front Ends to any electrode array can be made by contacting [Ripple](#).

## Samtec-Omnetics

The two most common array connector types are the Samtec 0.050" 36-pin terminal (ICS-style Utah arrays) and the Omnetics 0.025" 36-position terminal with 4 guide posts (Microprobe FMAs and U/V-Probes). The Samtec-to-Omnetics adapter (R01804), also known as the micro-to-nano adapter, can be used to connect the larger Front Ends (Micros and EMG) to electrode arrays that use the Omnetics nanostrip connector. The Omnetics-to-Samtec adapter (R01050), also known as the nano-to-micro adapter, can be used to connect the smaller Nano style Front Ends to electrode arrays that use the Samtec 36-pin connector. Be sure to mate Front Ends to the adapters so that the pin 1 markers align.

R01804 (Samtec-to-Omnetics)



R01050 (Omnetics-to-Samtec)

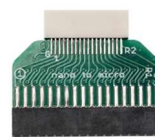

## Front End Cable Saver

The Front End Cable Saver adapter (R01610) can be used when connecting a Front End cable to fewer Front Ends than the cable requires. The adapter effectively takes the place of an active Front End allowing the port, cable, and Front Ends to be initialized correctly.

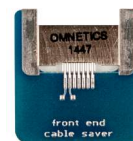

## Touchproof

The Grapevine Touchproof adapter (R01375, R01376) provides an interface between Front Ends and electrodes that terminate in 1.5 mm touchproof connectors. Adapter R01375 can be used with 32-channel single reference Front Ends, while adapter R01376 can be used with 16-pair differential Front Ends. The latest version of the Touchproof adapter has switches along the bottom that allow the user to ground unused channels.



## EMU

The Grapevine EMU 128 adapter (R01273) provides a dual connection for 32 channels of EEG/ECOG electrodes to a Grapevine processor and an XLTEK headbox. The EEG input signals are passed thru one passive DB-37 port to the XLTEK headbox and a Grapevine Micro recording Front End.





## Screw-Terminals for Single-Wire Electrodes

The Screw Terminal adapters (R01053, R01217, and R01407) connect each channel of a Front End (including references and ground) to a screw-terminal, for use with single-wire electrodes. R01053 and R01217 are for use with very few electrodes in a small form-factor and all unused channels are connected to ground. R01407 can be used with single-ended and differential Front Ends, and has small switches that can connect unused channels to ground to reduce environmental noise. Be sure to mate Front Ends to the adapters so that the pin 1 markers align.

R01217 4-Channel Screw Terminal  
(R01053 is similar but with Omnetics Nano Terminal)

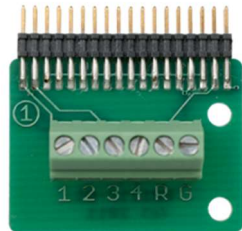

R01407 32-Channel Screw Terminal

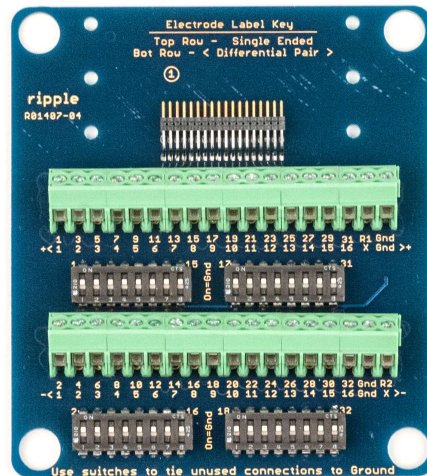

## Electrode Adapter Rod

The Electrode Adapter Rod (R01229) connects to many adapters through three small screws allowing the user to hold the adapter in place with a clamp similar to a chem-stand rod clamp.



## Analog I/O and Digital I/O Breakouts

The Grapevine Analog BNC Breakout adapter (R01124) converts the 24 input or output channels from the micro-D port of the Analog I/O FE to standard BNC terminals. The Grapevine Digital BNC Breakout adapter (R01396) converts the 16 digital input or output channels from the micro-D port of the Digital I/O FE to standard BNC terminals. The 16 channels of the Digital I/O can be configured as independent channels, a 16-bit bus with strobe, or two 8-bit busses with individual strobes.

R01124 Analog BNC Breakout



R01396 Digital BNC Breakout





## Utah Array Pedestal Connector

The Grapevine Utah Array Pedestal Connector (R03384) allows 4 Nano2 style Front Ends (up to 128 channels) to connect to a Utah array pedestal. The Grapevine Utah Array Pedestal Connector encloses the Nano2 FEs within a plastic housing in a strain-relieving manner. Each of the FEs within the connector housing must be attached such that the pin 1 markers of the Omnetics connectors align. The circular Front End connectors on each of the Nano2 FEs feed through the upper lid. Within the pedestal connector housing all Nano2 FEs are tied to the same reference. The switch near the array plug is used for reference selection (see bottom of Figure E-1).

**Note:** When using only 3 Front Ends for a 96-channel array, the open Omnetics connector must be occupied with a Spacer Block (R03436).

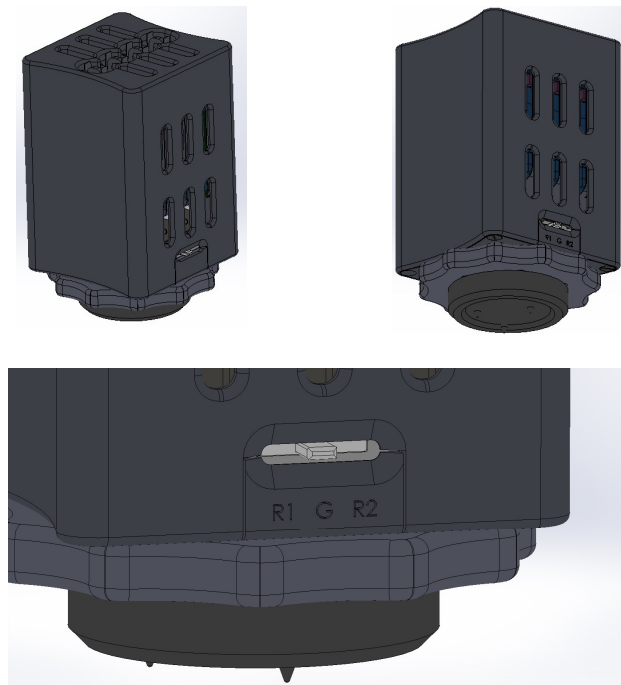

**Figure E-1** Views of R03384 Utah Array Pedestal Connector 128-Ch to Nano FE Adapter



## Recording Front End Tester

For recording Front Ends, a known signal, e.g., from a Function Generator, may be used as a test input to ensure that all Front End channels are working correctly. Part number R01404 (SMA to 36-pin Samtec) uses a 1000:1 voltage divider and connects the input signal to all 32 recording channels using either reference selection. The input test signal is stepped down by a factor of 1000 to ensure the safety of the recording amplifier; e.g., a  $\pm 5$  V sine wave input will be recorded as a  $\pm 5$  mV sine wave. There is also a differential version available (R01405) for use with differential Front Ends, such as the Grapevine EMG. The Omnetics to Samtec adapter (R01050) is required to acquire test signals with Nano style FEs, as shown in Figure E-2 on the right. Be sure to mate Front Ends to the adapters so that the pin 1 markers align.



Figure E-2 Recording Front End test-adapters and cables

## Stimulation Front End Tester

For stimulation Front Ends, a 10 k $\Omega$  test-load board (R01913) is included to allow users to test stimulation on all 32 channels with a known impedance load. Test-points are added to each channel location and ground, as shown in the image below, which can be useful for viewing the stimulation signal on an oscilloscope. The delivered stimulation voltage can also be acquired via Trellis by recording the stimulation data stream. Be sure to mate Front Ends to the adapter so that the pin 1 markers align (Micro+Stim FE in image below is rotated for display purposes).

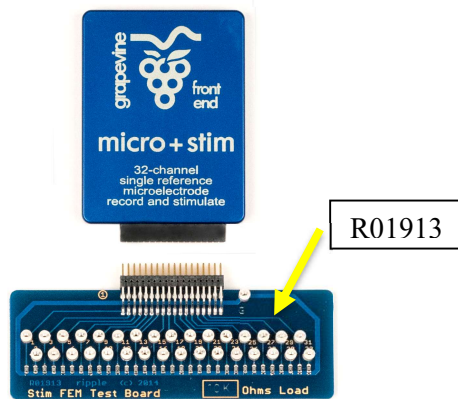

Figure E-3 Stimulation Front End load-test adapter

# Troubleshooting Guide



This appendix provides helpful hints and solutions for troubleshooting the Grapevine system and Trellis software suite. This appendix addresses issues that may not be consistent across all customers. Consistent, replicable problems will be addressed by Ripple engineers. This appendix will be updated with problems found by customers and solutions determined by Ripple. All solutions have been tested as much as possible by Ripple.

**Table F-1** Grapevine system troubleshooting solutions

Product	Error	Solution
Trellis 1.4.0 (Windows 7)	NIP not sending data packets. Network Status stuck at “searching”.	Disable Microsoft Security Essentials.
Trellis 1.4.0 (Mac OSX 10.8.4)	Installation failed to overwrite a previously installed Trellis software suite.	Erase the previously installed Trellis directory: Either from /Applications/Trellis or /Users/<username>/Applications/Trellis. Then install latest Trellis software suite.
NIP update 1.4.0	NIP failed to update because USB drive is improperly formatted from Mac machine.	Format USB drive to FAT32 using a Windows PC.
Trellis 1.4.0 (Mac OSX 10.9.x) Mavericks and newer	Network packet drops begin to occur when any Trellis application is opened and the Trellis main application is moved to the background.	Mac OSX 10.9.x and above has a feature called App Nap which regulates apps that it believes are not in use, to consume less power. Disable App Nap globally as detailed in Chapter 2.
Trellis 1.4.1 (Windows 7)	Installation fails because “The installer has insufficient privileges to access this directory: C:\Program Files\Ripple\Trellis\Tools\mksort\docs...”	Close MATLAB and retry. This occurs for mksort and/or xippmex if MATLAB is open.
Trellis 1.4.3 (Windows 7)	Error importing files into Plexon Offline Sorter – “error: unable to open C:\Program Files (x86)\Ripple\Trellis\ Tools\thirdparty\msNEVLibrary\x64\msNE VLibrary.dll”	Use of this file currently requires the installation of Visual C++ Redistributable for Visual Studio 2012. This package may be found <a href="#">here</a> and is available in x86 and x64 versions.
Trellis 1.4.3 (Windows 7)	Data packet loss even with properly configured low-latency gigabit network adapter.	Run msconfig by typing <window-key>-R, followed by msconfig. Select the "services" tab and click "Disable all" click apply. In the "general tab", select Normal. Reboot computer.
Trellis 1.6.0 (All OS)	Screen freezes, save functionality not working, selections not working, etc.	Delete *.ini files found in AppData. For Windows, delete all *.ini files in <InstallDir>\ Users\<user>\AppData\Roaming\Ripple\ For Mac/Linux, delete all *.ini files in \$HOME/.config/Ripple/.

# Revision History

---



- Version 01
  - Initial release
- Version 02
  - Addition of standards, specifications, warnings, warranty, and RMA process
  - Inclusion of size and weight for all Front Ends
  - Heat Map feature added to Trellis Spike Grid application
  - Safety Switch added to Trellis Stimulation Controller application
  - Screenshot updates
  - Inclusion of App Nap disable instructions for Mac OSX 10.9.x (Mavericks) users
- Version 03
  - Charge Balance parameter in Stimulation Controller Application changed to Phase Ratio for clarity and technical accuracy.
- Version 04
  - Addition of Test-Adapter Instructions Appendix
  - Addition of Front End cable use instructions
- Version 05
  - Updates to Chapter 1 and Appendix A to include new EMG Front End
  - Updates to Adapter Appendix to include additional adapters
  - Updates to File Save Application to include file segmenting
  - Updates to Impedance Analyzer Application to include Nano Front Ends
  - Updates to Windows and Macintosh configuration recommendations
  - Updates to Troubleshooting to include instructions for OFS and Windows Configuration
  - Inclusion of sample data location
- Version 06
  - Updates to Chapter 1, Chapter 3, and Appendix A to include new Nano2 Front End
  - Updates to Adapter Appendix for new touchproof adapter
  - Inclusion of new Appendix C – Hardware and Software Configuration
- Version 07
  - Updates to Chapter 1, Chapter 3, and Appendix A to include new Nano2-HV, and Nano2+Stim Front Ends
- Version 08
  - Updates to Chapter 1, Chapter 3, and Appendix A to include new Micro2, Micro2-HV, and Micro2+Stim Front Ends
  - Correction to Digital I/O output routing – removal of stimulation event markers – not currently functional
- Version 09
  - Updates to Troubleshooting
  - Return of stimulation event marker output
  - Inclusion of global map file
  - Inclusion of two-processor synchronization
  - Update of human-use for Nano2 style Front Ends
  - Updated instructions for use of v4.1 Offline Sorter

- Version 10 • Updated Nano/Micro+Stim(+Stim-HC)(-HV) Front End recording characteristics
- Version 11 • Include new section Network Info which explains UDP vs. TCP mode
- Version 12 • Addition of Grapevine Nomad  
• Addition of Analog+Digital I/O Front End  
• Addition of stimulation lookup tables to Chapter 3  
• Updated website download links throughout
- Version 13 • Updates to Adapter Appendix for Utah Array Pedestal Connector
- Version 14 • Addition of stimulation output tolerances for HC devices to Chapter 3
- Version 15 • Addition of Link 32 Front End
- Version 16 • Addition of Pico Front Ends  
• Updated information for Grapevine Nomad  
• Trellis now supported for Linux Ubuntu 18.04
- Version 17 • Updated website download links throughout  
• Addition of Pico16 pinout figure  
• Addition of Explorer EEG and ECoG+Stim Front Ends
- Version 18 • Grapevine Trek succeeds Grapevine Nomad  
• Updated Grapevine Trek Human Use Considerations  
• Updated information for Trek web application  
• Renamed Explorer ECoG+Stim to Explorer Macro+Stim